

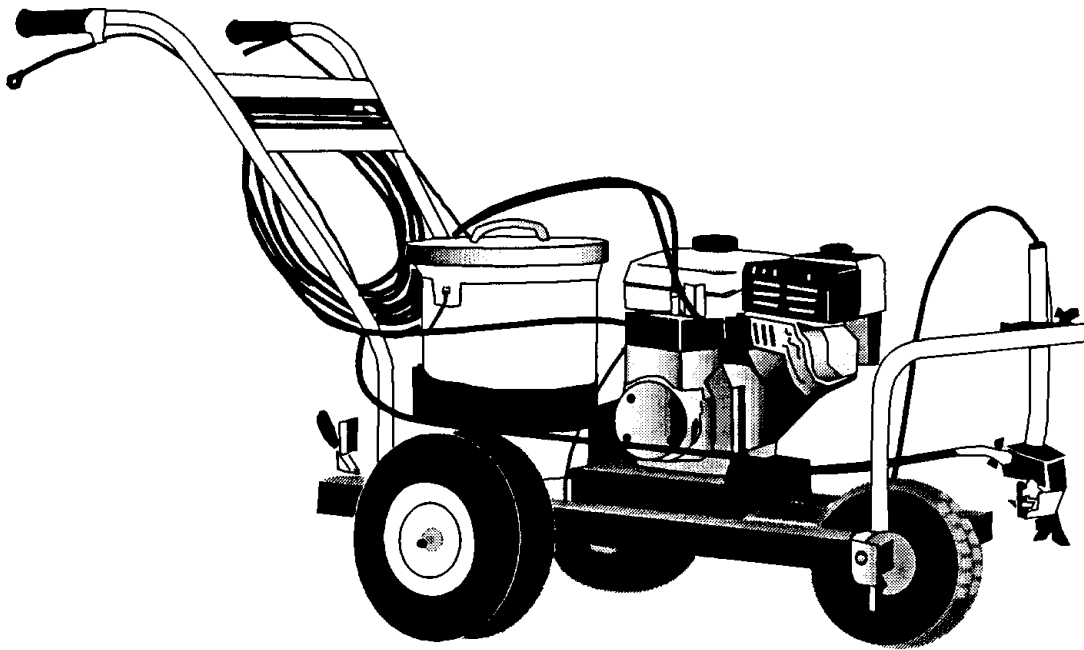

SURE STRIPE 3300

AIRLESS LINE STRIPER



OPERATION MANUAL AND PARTS LIST FOR MODEL AIRLESSCO SURE STRIPE 3300

WARNING: Before operating, doing any service or maintenance procedures, learn and follow the Pressure Relief Procedure on page 6. Read and understand all warnings on pages 4,5,6 and 7.

**ALL SERVICE PROCEDURES MUST BE PERFORMED
BY AUTHORIZED AIRLESSCO SERVICE CENTER.**

TABLE OF CONTENTS

INTRODUCTION	1
FLUSHING	1 & 2
SETTING UP	3
STARTING UP	4 & 5
LINE STRIPING TIP CHART	5
WARNINGS	5 - 8
SPRAY TECHNIQUE	9 - 10
LINE STRIPING OPERATION	11
007X & XL SPRAY GUN	12 & 13
AIRLESS SPRAY GUN OPERATION	14
TROUBLESHOOTING	15 & 16
EXCHANGE PROGRAM	16
LOW SPRAY PRESSURE TEST	17
PUMP HEAD ASSEMBLY	18
INSPECTION AND REPLACEMENT OF CONTROL HEAD	19
INSPECTION & REPLACEMENT OF CONTROL VALVE, BALL, SEAT	20
INSPECTION AND REPLACEMENT OF SUCTION VALVE	20
INSPECTION AND REPLACEMENT OF DISCHARGE VALVE	21
PRESSURE CALIBRATION	21
HANDLE ASSEMBLY ATTACHMENT PARTS LIST	22
GUN ARM ASSEMBLY ATTACHMENT	22
GUN ASSEMBLY	23
GUN HOLDER ASSEMBLY	24

INTRODUCTION

AIRLESSCO SURE-STRIPE 3300

This gas-powered, piston-diaphragm unit is designed to fulfill the dual role of professional linestriper and portable airless sprayer.

SPECIFICATIONS

Pressure 0 - 2500 psi
Output .7 gpm
Tip Size 1 gun up to 0.025
2 guns up to 0.017
Engine 5.5 hp Honda

WARNING

Prior to starting, read, understand and observe all safety precautions and warnings on cover & pages 5, 6, 7 & 8 and all labels and tags on the machine.

FLUSHING Read prior to using your sprayer

1. New Sprayer

Your Airlessco unit was factory tested in an anti-freeze solution which was left in the pump. Before using oil-base paint, flush with mineral spirits only.

Before using water-base paint flush with mineral spirits, followed by soapy water, then a clean water flush.

2. Changing Colors

Flush with a compatible solvent such as mineral spirits or water.

3. Changing from water-base to oil-base paint.

Flush with soapy water, then mineral spirits.

4. Changing from oil-base to water-base paint.

Flush with mineral spirits, followed by soapy water, then a clean water flush.

5. Storage

Oil-base paint: Flush with mineral spirits.

Water-base paint: Flush with water, then mineral spirits and leave the pump, hose and gun filled with mineral spirits.

For longer storage, use mixture of mineral spirit and motor oil (half & half). Shut off the sprayer, follow Pressure Relief Procedure on page 7 to relieve pressure and make sure prime valve is left OPEN. (fully counterclockwise) control.

6. Start up after storage

Before using water-base paint, flush with soapy water and then a clean water flush.

When using oil-base paint, flush out the mineral spirits with the material to be sprayed.

HOW TO FLUSH

FIG. 1

REMOVE
SPRAY
TIP

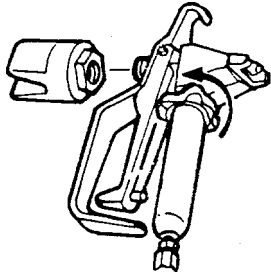

FIG. 2

CONTROL
VALVE



FIG. 3

Choke Lever
Fuel Valve
Throttle Lever

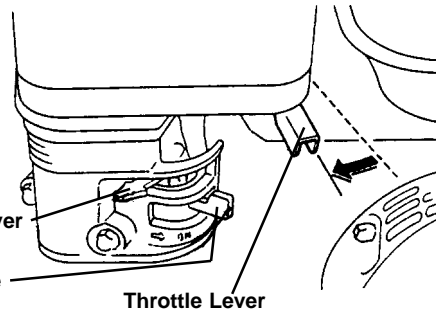

FIG. 4

MAINTAIN FIRM
METAL TO METAL
CONTACT BETWEEN
GUN AND CONTAINER



1. Be sure the gun safety latch is engaged and there is no spray tip in the gun. Refer to Fig. 1. Refer to your separate instruction manual provided with your gun on its safety features and how to engage safety latch.
2. Pour enough clean, compatible solvent into a large, empty metal pail to fill the pump and hoses.
3. Place the suction tube into the pail.
4. Turn the control valve to the prime position or fully counterclockwise.
5. Turn the engine ON/OFF switch to ON.
6. Move the choke to the closed position as per Fig.3.
7. Move the throttle lever slightly to the left as per Fig.3.
8. Turn the fuel valve ON as per Fig. 3. Pull the start rope. Pull the engine over against compression stroke and then let the rope rewind slowly into the starter. Pull firmly and rapidly to start the engine. Do NOT drop the rope. Hold onto the handle while rewinding, or the rope may rewind improperly and jam the assembly. If the engine does not start, open the choke half way. If the engine floods, open the choke all the way and continue cranking.
9. After the engine is warm, gradually open the choke lever, increase the RPM of engine by moving throttle all the way to the left.
10. Point the gun into the metal pail and hold a metal part of the gun firmly against the pail Refer to Fig. 4.

WARNING: To reduce the risk of static sparking, which can cause fire or explosion, always hold a metal part of the gun firmly against the metal pail when flushing. This also reduces splashing. Refer to Fig.4.

11. Disengage the gun safety latch and squeeze the gun trigger. Turn control valve clockwise just enough to move liquid at low pressure.
12. Allow the pump to operate until clean solvent comes from the gun.
13. Release the trigger and engage the gun safety latch.
14. If you are going to start spraying, place the or suction tube into the supply container. Release the gun safety latch and trigger the gun into another empty, metal container, holding a metal part of the gun firmly against the metal pail (Fig. 4) and force the solvent from the pump and hose. When paint starts coming from gun, turn control valve to prime or fully counterclockwise position and engage the gun safety latch.
15. If you are going to store the sprayer, remove the suction tube from the solvent pail force the solvent from the pump and hose. Engage the gun safety latch and refer to the "Storage" Procedure on page 1. Step 5.
17. Whenever you shut off the sprayer follow the Pressure Relief Procedure warning on page 7.

SETTING UP

1. Attach handle assembly.

Refer to Figure 5. Complete steps a - d for both sides of the handle.

- Slide plate (Item 1) over clamp (Item 2).
- Place clamp with plate attached over frame (Item 4), so that the holes in the clamp are in alignment with the holes in the frame.
- Put the handle (Item 5) down through the holes in the clamp and frame.
- Set handle to desired height and tighten the screw (Item 3) so that the plate is snug against the frame.

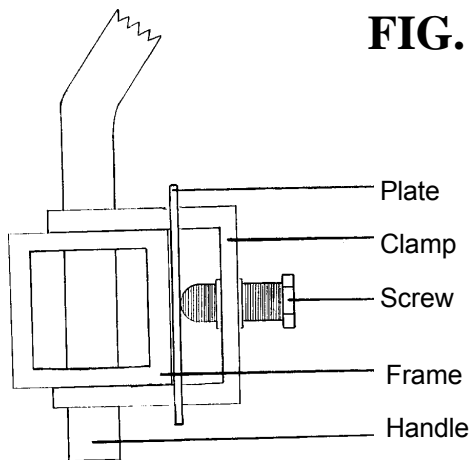

FIG. 5

2. Install the gun arm assembly.

Refer to Figure 6.

- Choose which side of the frame to mount the gun arm.
- Complete Steps a - c from attaching the handle assembly (above), except mounting the gun arm instead of the handle.
- Set gun arm to desired height and tighten the adjustable handle (Item 3) until the plate is snug against the frame. Note: The adjustable handle can be ratchet by lifting up on the handle.

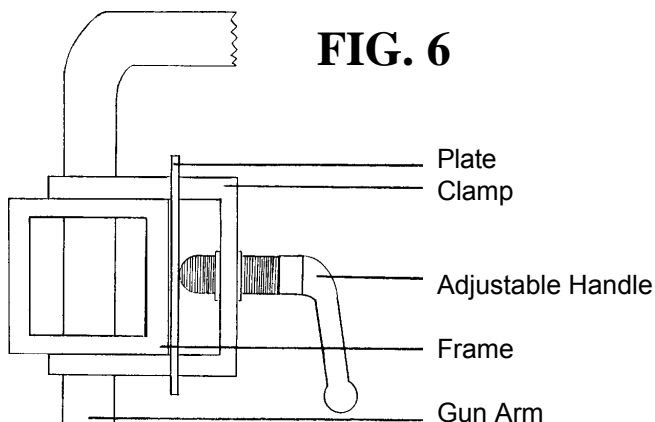

FIG. 6

3. Check the Engine Oil Level.

- Unscrew the oil fill plug. The dipstick is attached to the plug.
- Without threading the plug into place, check to be sure the oil is up to the top mark on the dipstick.
- If oil is needed, refer to engine manual.

NOTE: Unit is shipped WITH OIL in engine and clutch.

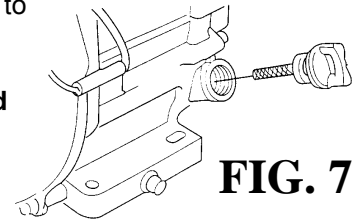

FIG. 7

4. Check Clutch Oil Level

- Complete steps a-c of Check the Engine Oil Level, except using the clutch dipstick.

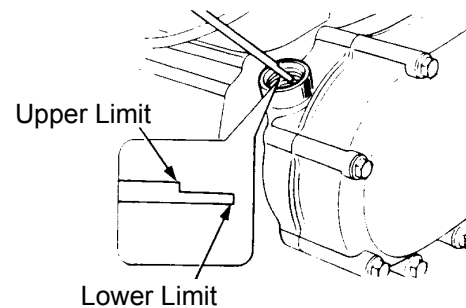

FIG. 8

5. Fill the Fuel Tank

WARNING: Fuel spilled on a hot surface can cause a fire or explosion and cause serious bodily injury and property damage. Always shut off the engine and let it cool before filling the tank, and carefully follow Steps a-c below, being sure not to spill any fuel.

- Close the fuel shutoff valve.
- Use only clean, fresh, well-known brands of unleaded regular grade gasoline.
- Remove the fuel cap and fill tank, Be sure the air vent in the fill cap is not plugged so fuel can flow to the carburetor, then replace the cap.

6. Flush the sprayer.

See "Flushing" page 1 & 2. Your new pump was factory tested in an ant-freeze solution and it must be flushed before using.

NOTE: Prior to striping, see Linestripping Operations (page 4) for correct gun arm set up, to get proper sized lines.

STARTING UP

1. Learn how to operate the control valve.

The control valve sets the prime or pressure position as well as the spraying pressure. When the valve is fully counter-clockwise the unit is in the prime position.

As the control valve is turned clockwise, the unit's output pressure to the gun is gradually increased until the control valve is fully clockwise and the unit is at 2500 psi.



FIG. 9

FOLLOW THE "PRESSURE RELIEF PROCEDURE ON PAGE 7 WHENEVER YOU:

- are instructed to relieve pressure.
- stop spraying
- checking or servicing any of the system equipment.
- or installing, servicing, or cleaning the spray tip.

HANDLE SPRAY SYSTEM AS YOU WOULD A LOADED FIREARM.

2. Prepare the Material

- Prepare the material according to the material manufacturer's recommendations.
- Place the suction tube into the material container.

3. Starting the Sprayer (See Fig 9)

- Control Valve must be in priming position or fully counterclockwise.
- Follow the procedure under "How to Flush", page 2, Steps 5 - 11.

WARNING: To stop the unit in an emergency or before performing any service or maintenance procedure follow the Pressure Relief Procedure on page 7 to relieve the fluid pressure.

4. Prime the Pump

- Allow pump to operate until paint comes from gun.
- Release the trigger and engage the gun safety latch.
- Turn Control valve to the prime position (Fully CCW) ensuring the pressure is released from the system.
- Install spray tip onto gun.
- Turn control valve clockwise to the desired spray pressure. (maximum 2500 psi)
- Disengage the gun safety lock and you are ready to start spraying.

WARNING: If you spray into the paint bucket, always use the lowest spray pressure and maintain firm metal to metal contact between gun and container. See page 2, Fig. 4.

5. Adjusting the Pressure

- Turn the Control Valve clockwise to increase pressure and counterclockwise to decrease pressure.
- Always use the lowest pressure necessary to completely atomize the material.

CAUTION: Operating the sprayer at higher pressure than needed wastes material, causes early tip wear and shortens sprayer life.

- If more coverage is needed use a larger tip rather than increasing the pressure.
- Check the spray pattern. The tip size and angle determines the pattern width and flow rate.

STARTING UP CONTINUED

6. Cleaning a Clogged Tip.

IMPORTANT

WARNING: Always follow the Pressure Relief Procedure on page 7 before performing any service or maintenance procedure.

WARNING: Never hold your hand, body, fingers, or hand in a rag in front of the spray tip when cleaning or checking it for a cleared tip. Always point the gun toward the front or into a waste container when checking to see if the tip is cleared or when using a self-cleaning tip.

- Follow the Pressure Relief Procedure on page 7.
- Clean the front of the tip frequently (with toothbrush only) during the day to keep material from building up and clogging the tip.
- To clean and clear a tip if it clogs, refer to the separate instruction manual received with your gun and nozzle.

There is an easy way to keep the outside of the tip clean from material build-up:

Everytime you stop spraying, for even a minute, lock the gun and submerge the gun nozzle into a small bucket of thinner comparable with the material sprayed.

Thinner will dissolve the build up of paint on the outside of tip, tip guard and gun much more effectively than if the paint dries out completely.

WARNING: Clogged standard flat tip - clean only after the tip is removed from the gun. Follow the Pressure Relief Procedure Warning on Page 7.

7. When Shutting Off the Sprayer

- Whenever you stop spraying, even for a short break, follow the Pressure Relief Procedure Warning on page 7.
- Clean the tip and gun as recommended by your separate gun instruction manual.
- Flush the sprayer at the end of each work day if the material you are spraying is waterbased, or if it could harden in the sprayer overnight. See "Flushing" page 1 and 2. Use a compatible solvent to flush, then fill the pump and hoses with an oil based solvent such as mineral spirits.
- For long term shutdown or storage, refer to page 1.

LINE STRIPING TIP CHART

NOTE: Striping Tips should not be used for regular spraying

FLAT STRIPING TIPS	REVERSIBLE STRIPING TIPS	ORIFICE SIZES	FAN (")	LATEX FAN WIDTH			OIL BASED FAN WIDTH		
				2-3	3-5	4-6	2-3	3-5	4-6
	550-213ST	.013	2 - 4					X	
102-115ST	550-115ST	.015	1 - 2				X		
102-215ST	550-215ST	.015	2 - 4					X	
102-315ST		.015	4 - 6						X
102-415ST		.015	6 - 8						X
102-117ST	550-117ST	.017	1 - 2	X					
102-217ST*	550-217ST*	.017	2 - 4		X				
102-317ST	550-317ST	.017	4 - 6			X			
102-417ST		.017	6 - 8						X
102-219ST	550-219ST	.019	2 - 4		X				
102-319ST	550-319ST	.019	4 - 6			X			
102-221ST	550-221ST	.021	2 - 4		X				
102-321ST	550-321ST	.021	4 - 6			X			

TIP REPLACEMENT:
During use, high pressure will cause the orifice to grow larger. This destroys the pattern or will leave tailing or two heavy lines on the outside of the pattern.
REPLACE SPRAY TIP FREQUENTLY!

WARNINGS

MEDICAL ALERT -

Airless Spray Wounds

If any fluid appears to penetrate your skin, get **EMERGENCY MEDICAL CARE AT ONCE. DO NOT TREAT AS A SIMPLE CUT.** Tell the doctor exactly what fluid was injected. Have him read the following "NOTE TO PHYSICIAN".

NOTE TO PHYSICIAN:

Injection in the skin is a traumatic injury. It is important to treat the injury **surgically** as soon as possible. **DO NOT DELAY** treatment to research toxicity. Toxicity is a concern with some exotic coatings injected directly into the blood stream. **Consultation with a plastic surgeon or reconstructive hand surgeon may be advisable.**

WARNINGS

HIGH PRESSURE SPRAY CAN CAUSE EXTREMELY SERIOUS INJURY.

OBSERVE ALL WARNINGS. THIS SPRAYER IS FOR PROFESSIONAL USE ONLY.

INJECTION HAZARD

Fluids under high pressure from spray or leaks can penetrate the skin and cause extremely serious injury, including the need for amputation.

NEVER point the spray gun at anyone or any part of the body.

NEVER put hand or fingers over the spray tip. Do not use rag or other materials over your fingers. Paint will penetrate through material and into the hand.

NEVER try to stop or deflect leaks with your hand or body.

ALWAYS have gun tip guard in place when spraying.

ALWAYS lock gun trigger when you stop spraying.

ALWAYS remove tip from the gun to clean it.

NEVER try to "blow back" paint, this is not an air spray sprayer.

ALWAYS follow the **PRESSURE RELIEF PROCEDURE**, as shown on page 7, before cleaning or removing the spray tip or servicing any system equipment.

Be sure equipment safety devices are operating properly before each use.

Tighten all fluid connections before each use.

MEDICAL TREATMENT

If any fluid appears to penetrate your skin, get **EMERGENCY CARE AT ONCE. DO NOT TREAT AS A SIMPLE CUT.**

* Go to an emergency room immediately.

* Tell the doctor you suspect an injection injury.

* Tell him what kind of material you were spraying with and have him read **NOTE TO PHYSICIAN** on page 5.

GENERAL PRECAUTIONS

NEVER alter equipment in any manner.

NEVER smoke while in spraying area.

NEVER spray highly flammable materials.

NEVER use around children.

NEVER allow another person to use sprayer unless he is thoroughly instructed on its' safe use and given this operators manual to read.

ALWAYS wear a spray mask, gloves and protective eye wear while spraying.

ALWAYS ensure fire extinguishing equipment is readily available and properly maintained.

NEVER LEAVE SPRAYER UNATTENDED WITH PRESSURE IN THE SYSTEM. FOLLOW PRESSURE RELIEF PROCEDURES ON PAGE 7.

TOXIC FLUID HAZARD

Hazardous fluid or toxic fumes can cause serious injury or death if splashed in eyes or on skin, inhaled or swallowed. Know the hazards of the fluid you are using. Store & dispose of hazardous fluids according to manufacturer, local, state & national guidelines.

ALWAYS wear protective eyewear, gloves, clothing and respirator as recommended by fluid manufacturer.

ALWAYS INSPECT SPRAYING AREA

Keep spraying area free from obstructions.

Make sure area has good ventilation to safely remove vapors and mists.

NEVER keep flammable material in spraying area.

NEVER spray in vicinity of open flame or other sources of ignition.

Spraying area must be at least 20 ft. away from spray unit.

SPRAY GUN SAFETY

ALWAYS set safety lock on the gun in "LOCKED" position when not in use and before servicing or cleaning.

DO NOT remove or modify any part of gun.

ALWAYS REMOVE SPRAY TIP when cleaning. Flush unit with **LOWEST POSSIBLE PRESSURE.**

CHECK operation of all gun safety devices before each use.

Be very careful when removing the spray tip or hose from gun. A plugged line contains fluid under pressure.

If the tip or line is plugged, follow the **PRESSURE RELIEF PROCEDURE** as outlined on page 7.

TIP GUARD

ALWAYS have the tip guard in place on the spray gun while spraying. The tip guard alerts you to the injection hazard and helps prevent accidentally placing your fingers or any part of your body close to the spray tip.

SPRAY TIP SAFETY

Use extreme caution when cleaning or changing spray tips. If the spray tip clogs while spraying, engage the gun safety latch immediately. *ALWAYS* follow the **PRESSURE RELIEF PROCEDURE** and then remove the spray tip to clean it.

NEVER wipe off build up around the spray tip.

ALWAYS remove tip & tip guard to clean **AFTER** pump is turned off and the pressure is relieved by following the **PRESSURE RELIEF PROCEDURE.**

KEEP CLEAR OF MOVING PARTS

Keep clear of moving parts when starting or operating the sprayer. Do not put your fingers into any openings to avoid amputation by moving parts or burns on hot parts.

Precaution is the best insurance against an accident.

When starting the engine, maintain a safe distance from moving parts of the equipment.

Before adjusting or servicing any mechanical part of the sprayer, follow the **PRESSURE RELIEF PROCEDURE** on page 7, and remove the ignition cable from the spark plug to prevent accidental starting of sprayer.

WARNINGS CONTINUED ON NEXT PAGE.....

WARNINGS continued

PRESSURE RELIEF PROCEDURE

To avoid possible serious bodily injury, including injection, always follow this procedure whenever the sprayer is shut off, when checking or servicing it, when installing or changing the tips, whenever you stop spraying or when you are instructed to relieve the pressure.

1. Engage gun safety latch. Refer to separate instruction manual provided with your gun on its safety features and how to engage safety latch.

2. Turn engine off.

3. Disengage safety latch & trigger gun to relieve residual fluid pressure. Hold metal part of the gun in contact with grounded metal pail



4. Re-engage gun safety latch

5. Turn Control Valve (Prime/Pressure Relief Valve) as shown open (priming) to relieve fluid pressure.



IF THE SPRAY TIP OR HOSE IS CLOGGED, follow Step 1 through 5 above. Expect paint splashing into the bucket while relieving pressure during Step 5. If you suspect that pressure hasn't been relieved due to damaged prime/pressure relief valve or other reason, engage gun safety and take to Authorized Airlessco Service Center.

Always follow recommended pressure & operating instructions.

HOSES

Tighten all fluid connections securely before each use. High pressure fluid can dislodge a loose coupling or allow high pressure spray to be emitted from the coupling and result in an injection injury or serious bodily injury.

Use only hose that has a spring guard. The spring guard helps protect the hose from kinks or other damage which could result in hose rupture and cause an injection injury.

NEVER use a damaged hose, which can result in hose failure or rupture and cause in injection injury or other serious bodily injury or bodily damage. Before each use, check entire hose for cuts, leaks, abrasion or bulging of cover, or damage or movement of couplings. If any of these conditions exist, replace the hose immediately. Never use tape or any device to try to mend the hose as it cannot contain the high pressure fluid. NEVER ATTEMPT TO RECOUPLE THE HOSE. High pressure hose is not recoupleable.

Help prevent damage to the hose by handling and routing carefully. Do not move the sprayer by pulling it with the hose.

LABELING

Keep all labels on the unit clean and readable. Replacement labels are available from manufacturer.

GROUNDING

Ground the sprayer and other components in the system to reduce the risk of static sparking, fire or explosion which can result in serious bodily injury and property damage.

Always ground all of these components:

1. Sprayer: Ensure grounding chain is in contact with the ground.
2. Fluid Hose: use only grounded hoses.
3. Spray gun or dispensing valve: grounding is obtained through connection to a properly grounded fluid hose and pump.
4. Object being sprayed: according to your local code.
5. All solvent pails used when flushing should only be metal pails which are conductive.

Once each week, check electrical resistance of hose (when using multiple hose assemblies, check overall resistance of unpressurized hose must not exceed 29 megohms (max) for any coupled length or combination of hose lengths. If hose exceeds these limits, replace it immediately.

Never exceed 500 Ft. (150 m.) overall combined hose length to assure electrical continuity.

NOTE: WARNINGS CONTINUE ON NEXT PAGE.

WARNINGS continued

AVOID COMPONENT RUPTURE

This sprayer operates at 2500 psi (170 bar). Always be sure that all components and accessories have a maximum working pressure of at least 3000 psi to avoid rupture which can result in serious bodily injury including injection and property damage.

NEVER leave a pressurized sprayer unattended to avoid accidental operation of it which could result in serious bodily injury.

ALWAYS follow the PRESSURE RELIEF PROCEDURE whenever you stop spraying and before adjusting, removing or repairing any part of the sprayer.

NEVER alter or modify any part of the equipment to avoid possible component rupture which could result in serious bodily injury and property damage.

NEVER use weak or damaged or non-conductive paint hose. Do not allow kinking or crushing of hoses or allow it to vibrate against rough or sharp or hot surfaces. Before each use, check hoses for damage and wear and ensure all fluid connections are secure.

REPLACE any damaged hose. NEVER use tape or any device to mend the hose.

NEVER attempt to stop any leakage in the line or fittings with your hand or any part of the body. Turn off the unit and release pressure by following PRESSURE RELIEF PROCEDURE on page 7.

ALWAYS use approved high pressure fittings and replacement parts.

ALWAYS ensure fire extinguishing equipment is readily available and properly maintained.

WARNING

Do not use halogenated solvents in this system. The prime valve, 2 gun manifold and most airless guns have aluminum parts and may explode. Cleaning agents, coatings, paints or adhesives may contain halogenated hydrocarbon solvents. DON'T TAKE CHANCES! Consult your material suppliers to be sure. Some of the most common of these solvents are: Carbontetrachloride, Chlorobenzene, Dichloroethane, Dichloroethyl Ether, Ethylbromide, Ethylchloride, Tetrachloroethane. Alternate valves and guns are available if you need to use these solvents.

PREVENT STATIC SPARKING FIRE/ EXPLOSIONS

ALWAYS be sure all equipment and objects being sprayed are properly grounded. Always ground sprayer, paint bucket and object being sprayed. See "grounding" on page 7 for detailed grounding information.

Vapors created when spraying can be ignited by sparks. To reduce the risk of fire, always locate the sprayer at least 20 feet (6 m.) away from the spray area. Do not plug in or unplug any electrical cords in the spray area, which can create sparks, when there is any chance of igniting vapors still in the air. Follow the coating & solvent manufacturers safety warnings and precautions.

Use only conductive fluid hoses for airless applications. Be sure gun is grounded through hose connections. Check ground continuity in hose & equipment. Overall (end to end) resistance of unpressurized hose must not exceed 29 megohms for any coupled length or combination of hose length. Use only high pressure airless hoses with static wire approved for 3000 psi.

FLUSHING

Reduce the risk of injection injury, static sparking or splashing by following the specific cleaning procedure on pg. 2.

ALWAYS follow the PRESSURE RELIEF PROCEDURE on page 7.

ALWAYS remove the spray tip before flushing. Hold a metal part of the gun firmly to the side of a metal pail and use the lowest possible fluid pressure during flushing.

NEVER use cleaning solvents with flash points below 140 degrees F. Some of these are: acetone, benzene, ether, gasoline, naphtha. Consult your supplier to be sure.

NEVER SMOKE IN THE SPRAYING/CLEANING AREA.

GAS ENGINE PRECAUTIONS

Locate unit 25 feet away from spray area in well ventilated area. NEVER operate in closed building unless exhaust is piped outside. NEVER allow hose to lay against engine mufflers or hot parts. NEVER refill fuel tank while engine is hot or is running.

Important: United States Government safety standards have been adopted under the Occupational Safety & Health Act. These standards, particularly the General Standards, Part 1910, & the Construction Standards, part 1926 should be consulted.

WHEN SPRAYING & CLEANING WITH FLAMMABLE PAINTS OR THINNERS:

1. When spraying with flammable liquids, the unit must be located a minimum of 25 feet away from the spraying area in a well ventilated area. Ventilation must be sufficient enough to prevent the accumulation of vapors.
2. To eliminate electrostatic discharge, ground the spray unit, paint bucket and spraying object. Use only high pressure airless hoses approved for 3000 psi which is conductive.
3. Remove spray tip before cleaning gun and hose. Make contact of gun with bucket and spray without the tip in a well ventilated area, into the grounded steel bucket.
4. Never use high pressure in the cleaning process. USE MINIMUM PRESSURE.
5. Do not smoke in spraying/cleaning area.

SPRAY TECHNIQUE - REGULAR AIRLESS SPRAYING

Good Spray Gun Technique is at the core of any spray paint operation. Operator skill and efficiency is as important as good equipment and good paint. Good spray technique is a skill that can be quickly learned by following these simple instructions.

If you are not familiar with spraying techniques, we recommend that you study this section of your manual and practice the proper technique on pieces of cardboard or a suitable surface.

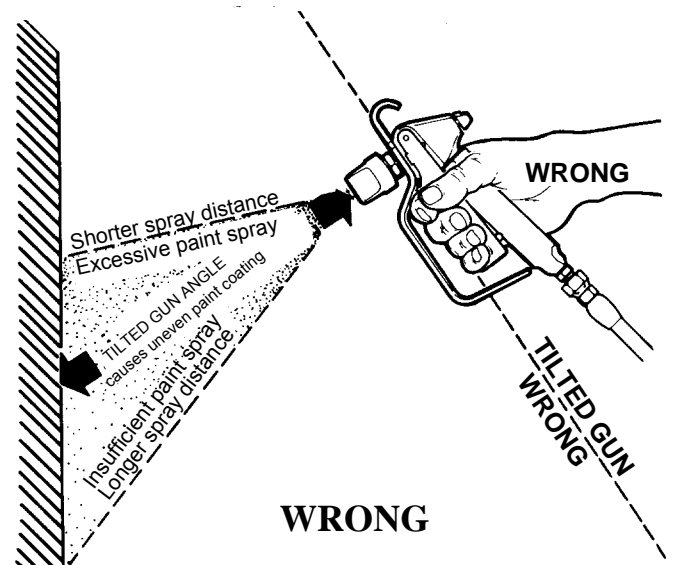
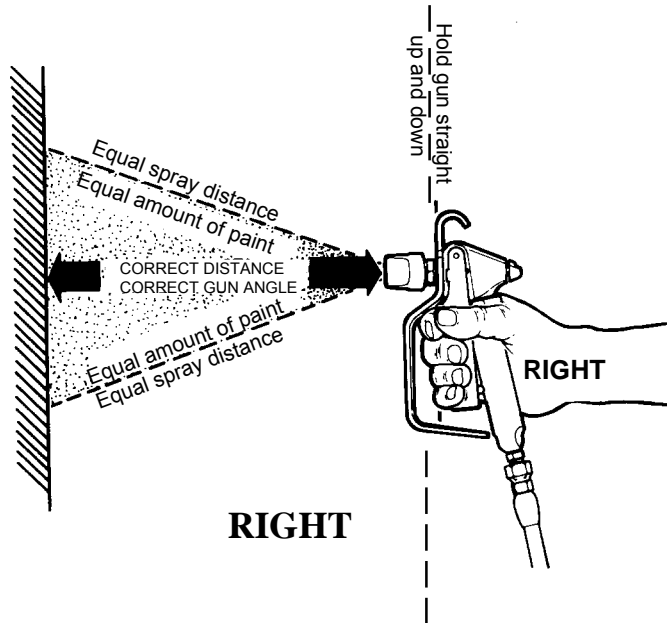

Hold the spray gun 12 - 15 inches away from the work surface and keep it perpendicular (straight) to the surface. Move the spray gun parallel to the work and at a right angle to the surface.

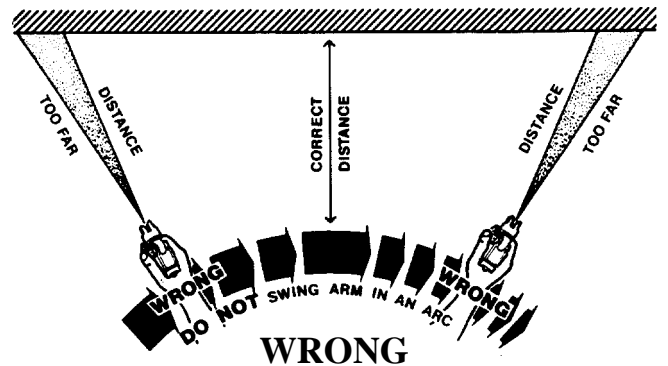
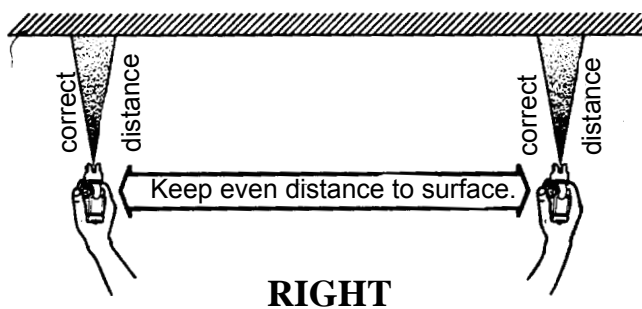

Move the gun at a steady rate in order to apply a good coverage. The wet coat should be just under the thickness at which a run or sag will occur. Slow gun movement or gun held too close will result in an overly wet or thick wet or thick coat coverage that is likely to run or sag.

The closer the spray gun is held to the work, the thicker the paint is deposited and the faster the gun must be moved to prevent sags and runs. Holding the gun too far from the work will cause excessive fog, overspray, and a thin and grainy coat.

Do not wave the spray gun. This waving is called arching. Instead, hold the spray gun at a 12 to 15 inch distance perpendicular from the work.

SPRAY TECHNIQUE - REGULAR AIRLESS SPRAYING

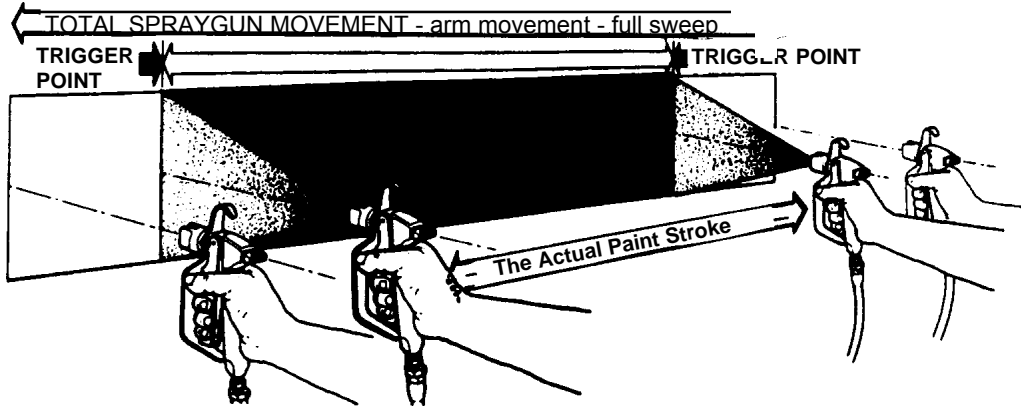

It is important to "trigger" the gun after gun movement (arm movement) has started and release trigger (shut gun off) before gun movement ends. Gun movement is always longer than actual paint (spray) stroke. In that manner, even blending and uniform paint coat thickness is achieved over the entire surface. When the gun is in motion as the trigger is pulled, it deposits an even amount of paint.

Spray with uniform strokes from left to right and from right to left, holding stroke speed, distance, lapping, and triggering as uniform as possible.

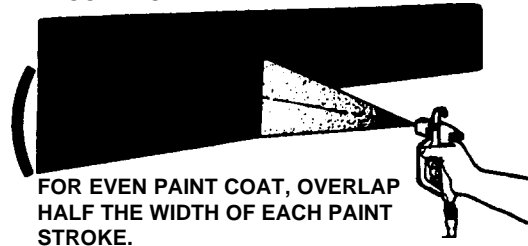

Overlap the previous pass by half the width of the spray pattern. Aim at the bottom of the previous pass.

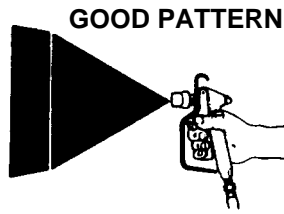
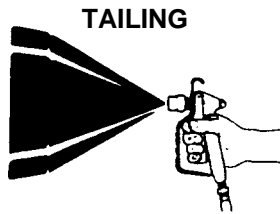

Adjust pressure control knob so that paint is completely atomized from the spray gun. Insufficient pressure will result in "tailing".

Too much pressure will result in excess fog and overspray, excessive tip wear, and increased sprayer wear and tear.

POOR PATTERN

GOOD PATTERN

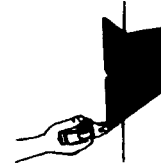
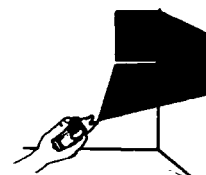
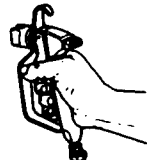

INSIDE CORNER

OUTSIDE CORNER

Always use the lowest pressure possible to obtain desirable results.

"Inside" and "outside" corners can be sprayed.

Test the spray pattern on a piece of cardboard or other surface.

Aim the spray gun toward the center of the corner. The spray pattern is divided in half, and the edges of the spray pattern on both walls are the same.

LINE STRIPING OPERATION

1. Choose handle location.

The choices are, installing the handle opposite of the single wheel (standard set up) or placing the handle directly over the single wheel. The handle location is really a matter of personal preference. However having the handle away from the single wheel assembly allows for easier loading/unloading from a van or truck.

2. Choose the gun arm position.

There are six holes in the frame for mounting the gun arm. In a standard set up (handle away from the single wheel), the gun arm would be mounted in one of the two mounting holes near the single wheel. This allows for an easier visual check for straight line striping. Experiment with different combinations to find the set up that you prefer.

3. Setting up the gun(s).

- a. Ensure that striping tip(s) are in the gun(s).
- b. Pick a tip size for the desired line width. Example: a 217ST tip for a four inch line.
- c. Place gun into the gun holder, so that the top of the taper on the gun handle is flush with edge of the gun holder.
- d. Set gun height for the desired line width. Adjust height by loosening the small black handle on the gun holder assembly and slide the gun arm to the correct height. Now tighten the handle. This will require some experimentation to find the correct height. It is suggested that tape, or some other method, is used to mark the height of commonly used settings.
- e. If using two guns, set spacing between the two guns by loosening the black handle on the gun arm, slide to the desired width and tighten.
- f. Attach the swivel heads to the gun(s) if painting curbs or wide stripes.
- g. Angle the gun(s) slightly forward. This allows the spray pressure from the gun(s) to help blow dirt and debris out of the path of the new stripes.

4. Cable Tension Adjustment

Once the handle and gun arm assemblies are set up to the preferred positions, pressurize the unit and trigger each gun to ensure that they activate and release correctly. If not, adjust the cable tension as follows:

- a. Locate the adjustment knobs on the base of the gun lever assembly, where the cable connects to the gun lever assembly.
- b. Loosen the locking nut and move the adjusting screw until the slack has been removed from the cable.

- c. Tighten locking nut and pull the gun lever(s) and ensure proper gun function.

Note: There is an additional cable adjustment where the cable attaches to the gun holder assembly. Use only if the gun lever adjustment is insufficient.

5. Miscellaneous Operations

- a. **CURBS:** Adjust gun to desired height and turn swivel head towards curb.
- b. **WIDE STRIPES:** Install wider fan striping tips and raise the gun height to achieve the desired width line. Also angle guns slightly towards each other to get an even coat of paint.
- c. **CURVES AND ARCS:** Move gun arm to the mounting hole on the frame next to the larger wheel and secure arm. SET-UP instructions on page 3. Press down on handle to lift the weight off the front single wheel and push the unit through the desired arc. This procedure requires some practice in order to achieve the best results.
- d. **STENCILS:** Install standard spray tip on the outer gun, which has the 50 foot paint hose attached. Remove this gun from the gun holder and spray out the stencils.
- e. **STANDARD PAINTING:** Same as stencils, but use additional paint hose as required.

007X & 007XL SPRAY GUNS

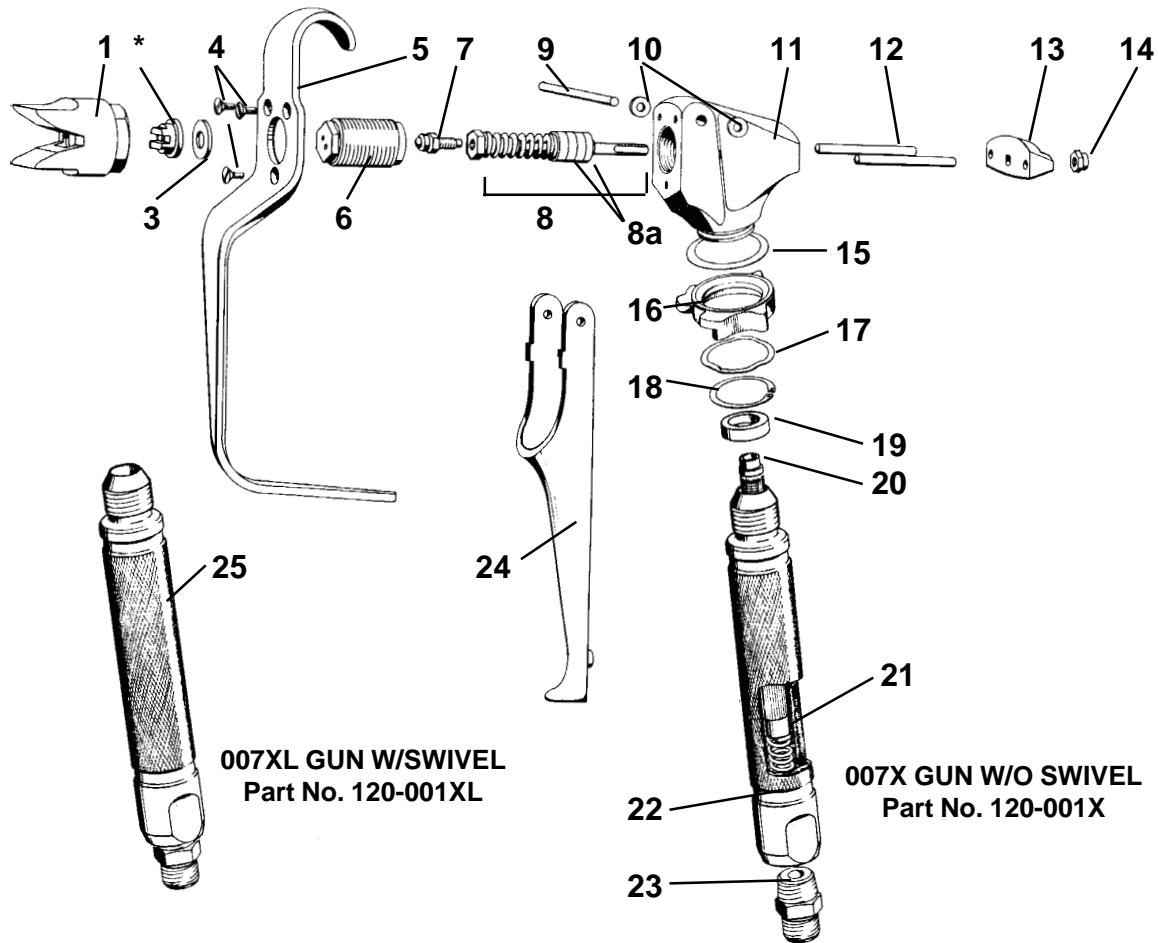

007XL GUN W/SWIVEL
Part No. 120-001XL

007X GUN W/O SWIVEL
Part No. 120-001X

SPRAY GUN PARTS LIST

ITEM NO.	PART NO.	DESCRIPTION	ITEM NO.	PART NO.	DESCRIPTION
1	120-036	Tip Holder with Guard	14	120-021	Nut
2		Deliberately Omitted	15	120-056	Washer
3	120-008	Tip Washer	16	120-048	Lock
4	120-023	Screw (3)	17	120-055	Wave Washer
5	120-005	Guard	18	120-049	Retaining Ring
6	120-035	Valve Seat Complete	19	120-082	Seal
7	120-037	Valve Ball with Holder	20	120-090CX	Filter-Complete-Coarse
8	120-011	Valve Spring Unit	20	120-090FX	Filter-Complete-Fine
8a	120-033	Seals PTFE (2)	21	120-088	Spring
9	120-022	Trigger Pin	22	120-087	Handle Complete 007X
10	120-046	Washer (2)	23	115-019	Connector
11	120-002	Gun Head	24	120-044	Trigger
12	120-045	Retainer Pin (2)	25	120-085	Handle with Swivel 007XL
13	120-020	Retainer	*		Tungsten Carbide Spray Tip (See Spray Tip Selection)

AIRLESSCO 007X & 007XL SPRAY GUN

ADJUSTING SPRAY GUN

Hold gun with trigger locked (24) and push trigger against the lock (16). Then adjust nut (14) so that the retainer (13) will move freely back and forth approximately 1/32" to allow valve spring unit (8) to seat the valve ball (7).

IMPORTANT: Readjust nut (14) periodically for wear of valve seat (6) and valve ball (7); otherwise, leakage will occur.

TO REPLACE THE VALVE BALL HOLDER (7)

KIT #2-007

3 Tip Washers (3) 1 Valve Seat (6)
1 Valve Ball Holder (7) 2 Seals- PTFE (8a)

Dismantling:

1. Unscrew tip holder (1) with a 7/8" open end wrench. Remove spray tip and washer (3).
2. Unscrew valve seat (6) with 1/2" socket wrench.

Caution

When removing and replacing valve seat (6), hold the trigger (24) in the open position so that the valve ball (7) is lifted off the valve seat. Failure to lift the ball off the seat will result in a scratched leaky valve.

3. Unscrew valve ball (7) together with the brass part of the assembly (8). Do not pull on the parts or the packing may get damaged.
4. Unscrew the valve ball (7) from the brass part of the assembly (8).

Reassembling is done in reverse sequence. Screw the new valve ball with holder (7) into the brass part (8).

Caution

Tighten valve ball and brass part on threaded end of the shaft by hand until you feel a positive stop. Do not tighten with a wrench since this could result in breaking the shaft.

Note it is recommended that you change the valve seat (6) and valve ball (7) at the same time.

REPLACING THE VALVE SPRING UNIT (8)

KIT#3-007

3 Tip Washers (3) 1 Valve Seat (6)
1 Valve Ball Holder (7) 1 Valve Spring Unit (8)

1. Repeat dismantling procedure as outlined above under Steps 1 through 3.
2. Unscrew nut (14), remove retainer (13) with retainer pins (12) and push shaft of the valve spring unit (8) out of the gun head (11).
3. Clean gun head (11) bore with solvent and small brush. Do not use any sharp objects to scrape away dried paint, as they would cause leakage around the seal.

Reassembling is done in reverse sequence.

IMPORTANT: When reassembling, install valve spring unit (8) with spring loose.

Push firmly into gun head by hand. Install retainer pins (12), retainer (13) and nut (14) loosely onto valve spring unit (8). Place a 3/16" nut driver on front of valve spring unit and turn clockwise, tightening the valve spring unit until you feel a positive stop. At that point, continue tightening the valve spring another 1/8 turn expanding the PTFE seals against body of gun.

Caution

Do not tighten beyond 1/8 turn as this can result in breaking the valve spring unit shaft. Continue reassembly and adjustment as described above.

CLEANING 007 SPRAY GUN

Immediately after the work is finished, flush the gun out with a solvent. Brush pins (12) with solvent and oil them lightly so they will not collect dried paint.

CLEANING SPRAY TIP

Should the spray tip become clogged, relieve pressure from hoses by following the "Pressure Relief Procedure" in Machine Manual, secure the gun with safety lock (16), take off tip holder (1), take out the tip, soak in appropriate solvent & clean with a brush. (Do not use a needle or sharp pointed instrument to clean the tip. The tungsten carbide is brittle and can chip.)

CLEANING FILTER

To clean the filter, use a brush dipped in as appropriate solvent. Change or clean filters at least once a day. some types of latex may require a filter change after four hours of operation.

AIRLESS SPRAY GUN OPERATION

<u>DEFECTS</u>	<u>CAUSE</u>	<u>CORRECTION</u>
Coarse spray	Low pressure	Increase the pressure.
Excessive fogging distribution. (overspray)	High pressure Material too thin	Reduce the pressure to satisfactory pattern Use less thinner.
Pattern too wide	Spray angle too large	Use smaller spray angle tip.
Pattern too narrow	Spray angle too small	Use larger spray angle tip. (If coverage is OK, try tip in same nozzle group)
Too much material	Nozzle too small Material too thin Pressure too high	Use next smaller nozzle. Reduce pressure.
Too little material	Nozzle too small Material too thick	Use next larger nozzle.
Thin distribution in center of pattern "horns".	Worn tip Wrong tip	Change for new tip. Use nozzle with a narrow spray angle.
Thick skin on work nozzle	Material too viscous Application too heavy	Thin cautiously. Reduce pressure and/or use tip in next larger group.
Coating fails to close & smooth over	Material too viscous	Thin cautiously.
Spray pattern irregular, deflected	Orifice clogged. Tip damaged	Clean carefully. Replace with new tip.
Craters or pock marks, bubbles on work	Solvent Balance	Use 1 to 3% "short" solvents remainder "long" solvents (this is most likely to happen with material of low viscosity, lacquers, etc.)
Clogged screens	Extraneous material in paint. Coarse pigments Poorly milled pigments paint pigments glocculate cover screen. Incompatible paint mixture and thinner.	Clean screen Use coarse screen if orifice size allows. Use coarser screen, larger orifice tips. Obtain ball milled paint. If thinner has been added, test to see if a drop placed on top of paint mixes or flattens out on the surface. If not, try different thinner in fresh batch of paint.

TEST THE PATTERN

Good, full



Spotty Pattern
Increase Pressure.

TROUBLESHOOTING

<u>PROBLEM</u>	<u>CAUSE</u>	<u>SOLUTION</u>
Engine not running.	<ol style="list-style-type: none"> 1. No gas in the tank or gas valve closed. 2. Cold start without choke. 3. No oil in engine. 4. Loose spark plug. 	<p>See Engine Manual</p> <p>Set choke and start. Refill Tighten or replace.</p>
Unit does not prime.	<ol style="list-style-type: none"> 1. Air in the system. 2. Paint too heavy. 3. Filter dirty or plugged. 4. Valve ball and seat stuck or fouled by corrosion, dried paint or other foreign material. 5. Engine throttle too low to engage clutch. 	<ol style="list-style-type: none"> 1. Turn Control Valve counterclockwise to "Prime" and wait until system is free of air. 2. Thin paint. 3. Clean or replace filter. 4.a. Inspection and replacement of suction valve. See Page 20. b. Inspection and replacement of control valve. See Page 20. c. Inspection and replacement of discharge valve. See page 21. 5. Increase engine throttle. See engine manual.
Unit primes, but pressure does not build up. (Important: check with pressure guage.)	<ol style="list-style-type: none"> 1. Control (prime) valve open. 2. Air in system. 3. Excessive wear of or dirt in Control Valve Seat and Ball. 4. Misadjusted control valve. 	<ol style="list-style-type: none"> 1. Turn control valve clockwise. 2. Turn control valve counterclockwise to "Prime" and wait until system is free of air. 3. Clean or see instructions for inspection and repair of control valve. 4. See instructions for Pressure Calibration. See page 21.
Unit primes, pressure builds up, but drops immediately when gun is opened. (Important: check with pressure guage.)	<ol style="list-style-type: none"> 1. Too large tip size. 2. Inlet filter plugged. 3. Paint too heavy. 4. Suction hose clamps not tight, pump sucking air. 5. Suction hose defective. 6. Control seat and ball worn. 7. Paint leaks through bleeding hole in casting. 8. If none of above improved spraying. 	<ol style="list-style-type: none"> 1. Exchange tips for smaller size. Tips wear out after some time, enlarging the orifice. 2. Clean or replace filter. 3. Thin or filter paint. 4. Tighten clamps. 5. Replace suction hose. 6. See instructions for inspection and replacement of Control Valve. 7. Replace diaphragm assembly. 8. Take your unit to an Authorized Airlessco Service Center.
Unit primes, pressure builds up, but does not maintain pressure while spraying.	Control or discharge valve worn or obstructed.	Conduct Low Spray Pressure Test. See page 17.

CONTINUED ON NEXT PAGE.....

TROUBLESHOOTING continued...

<u>PROBLEM</u>	<u>CAUSE</u>	<u>SOLUTION</u>
Oil leaking out of weep hole.	Small amount of oil leaking out of the weep hole is normal.	None
Oil blowing out of weep hole.	Diaphragm installed with hole facing weep hole instead of towards engine.	Inspection and replacement of diaphragm. See page 19.
Paint leaking out of weep hole.	Diaphragm failed.	Conduct Low Spray Pressure Test. See page 17.

EXCHANGE PROGRAM

The following items are part of the Airlessco Exchange Program.

Control head (115-101)
Diaphragm Assembly (114-001)
Control Valve (115-024)

When purchasing these items rebuilt, there is a core credit for the used parts. This reduces maintenance costs and downtime. Contact Airlessco or your local distributor for details.

LOW SPRAY PRESSURE TEST

STEP 1: CHECK CONTROL VALVE, using 50' flexible hose and pressure gauge.

Prime pump at full speed of engine.

Adjust maximum pressure.

Change speed to idle or turn off engine.

PRESSURE DROPS
IMMEDIATELY TO "O" PRESSURE
CHANGE CONTROL BALL AND SEAT.

PRESSURE DROPS 1000-1500
AND STOPS DROPPING OR SLOWS
DOWN AND CONTINUES TO DROP
TO "O" PRESSURE. **GO TO STEP 2.**

STEP 2: CHECK DISCHARGE VALVE AND SUCTION VALVE

Inspection and replacement of Discharge and Suction Valves.

See page 20-21.

If Spray Pressure still low go to Step 3.

STEP 3: CHECK DISCHARGE BALL STOP

Prime pump.

Adjust maximum pressure.

Spray with .017 tip.

Record spraying pressure.

Turn control knob to prime.

Turn motor switch off.

Replace Discharge Ball Stop.

Prime pump

Adjust maximum pressure

Spray with .017 tip.

SPRAYING PRESSURE DIDN'T
IMPROVE - STILL LOW

SPRAYING PRESSURE IMPROVED.

Replace Control Head. See page 19.
See Exchange Program, page 16.

Leave new Discharge Ball Stop in place.

PUMP HEAD ASSEMBLY - 115-101

FIG. 10

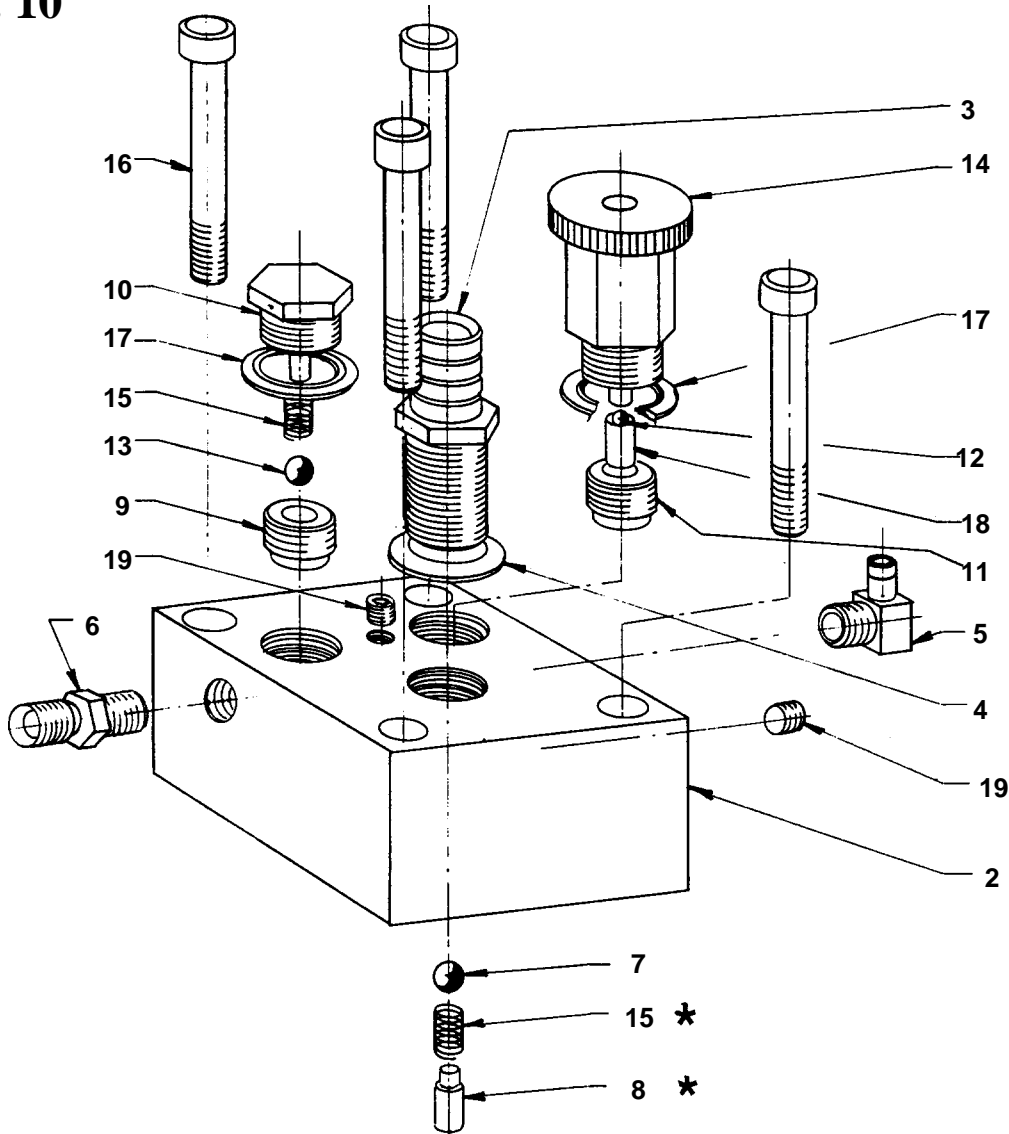

ITEM NO.	PART NO.	DESCRIPTION	ITEM NO.	PART NO.	DESCRIPTION
1	115-101	Pump Head- Ass'y	10	115-007	Discharge Valve Ball Stop
2	115-102	Pump Head	11	115-016	Control Valve Seat
3	115-105	Suction Seat Ass'y	12	115-017	Control Ball 7/32" Dia.
4	145-006	Seal Washer	13	115-050	Discharge Ball 11/32" Dia.
5	115-107	Elbow	14	115-024	Pressure Control Valve
6	115-019	Fitting	15	115-025	Spring *
7	115-022	Suction Valve Ball 5/16"Dia	16	115-027	Screw
8	114-010	Suction Valve Ball Stop *	17	115-028	Ring Seal
9	115-004	Discharge Valve Seat	18	115-031	T.C. Guide
			19	115-034	Plug

* Not part of pump head assembly.

INSPECTION AND REPLACEMENT OF CONTROL HEAD

See Figure 10

1. Inspect the control head components in accordance with the procedures for inspecting the discharge, suction and control valves. See page 20-21.
2. Disconnect suction, prime and gun hoses. See page 28.
3. Remove the four bolts (item 16) and the control head. Look at the ring insert on the under side of the control head to ensure that there is no damage to it.
4. Remove old suction ball (item 7) from diaphragm spring (item 15).
5. Ensure diaphragm spring is 5/16" above the top of the diaphragm.
6. Cycle new diaphragm to the bottom of its stroke, by spinning the motor fan with a screwdriver.
7. Set new suction ball onto diaphragm spring.
8. Look down into suction seat assembly (item 3), while placing new control head (if required) onto bearing housing. Make sure suction ball is not knocked off the diaphragm spring, while mounting control head.
9. Insert and alternately tighten the four bolts (item 16) to 45 ft-lbs.
10. Re-install suction, prime and gun hoses.

REPLACEMENT OF DIAPHRAGM

See Figure 10

1. Complete steps 2-4 of Inspection and replacement of Control Head.
2. Cycle diaphragm to the top of its stroke, by spinning the motor fan with a screw driver. Finding the top of the stroke is best determined by placing your thumb on the diaphragm while turning the motor fan.
3. Pryout the old diaphragm by inserting a screwdriver under the white plastic seals of the diaphragm. NOTE: There will be a slight vacuum hold on the diaphragm.
4. Inspect inside of bearing housing so that the oil is clean (no paint) and full (6 ounces). If oil is unclean or needs filling, complete step 2 of Replacement of Oil Seal. See page 23.
5. Remove snap ring and slide bronze bushing out of the bearing housing. Inspect bushing for wear.
6. Soak bushing in warm light weight oil. Slide bushing back into bearing housing and secure with snap ring.
7. Insert exchange diaphragm into bearing housing with the hole in the side of the diaphragm facing the engine (away from the weep hole).
8. Press diaphragm down and rotate motor fan with a screwdriver until diaphragm is at the bottom of its stroke.
9. Ensure that the diaphragm spring is 5/16" above the top of the diaphragm.
10. Complete steps 7 -10 of Inspection and Replacement of Control Head.

NOTE: The diaphragm should be replaced when:

1. Control Head is removed for any reason.
2. Paint leaks out of weep hole. (Oil leaking out of weep hole is normal).
3. Paint is leaking between the control head and bearing housing.

INSPECTION AND REPLACEMENT OF CONTROL VALVE, BALL AND SEAT

See Figure 10.

1. Use a wrench to unscrew the control valve (item 14) with ring seal (item 17).
2. Make sure that the control valve knob turns freely and that its stem is not worn unevenly, mushroomed or otherwise damaged.
3. Remove TC guide (item 18), verify that it is unbroken, clean and notch side is up.
4. Remove control ball (item 12). Inspect for any cuts, scratches, chips, rust or other damage.
5. Use a 7/16" allen wrench to unscrew the control seat (item 11) from the pump head (item 2). Clean seat and inspect bevel edge for damage. Also ensure that the gasket on the underside of the seat is intact.
6. If no obvious damage to the control ball and seat, place ball into seat and fill with water. If water leaks out between ball and seat, they must be replaced.
7. Replace control valve, ball, seat and/or TC guide as necessary.
8. Clean and inspect pump head opening, where the control seat was installed.
9. Grease pump head opening with multipurpose grease.
10. Screw control seat into pump head and torque to 85 ft-lbs.
11. Place TC guide into control seat with notched side up.
12. Drop control ball into TC guide.
13. Screw control valve with ring seal into pump head. Torque to 15 ft-lbs.
14. If a new control valve, ball or seat is installed, complete the Pressure Calibration Procedure. See page 21.

A repair kit with the control ball and seat is available as KIT-3-3100.

INSPECTION AND REPLACEMENT OF SUCTION VALVE

See Figure 10

1. Remove suction hose assembly from suction seat assembly (item 3) by loosening the hose clamp
2. Place a small screwdriver into the suction seat assembly and onto the suction valve ball (item 7). Turn the machine "ON". The screwdriver should oscillate about 1/16" inch. This indicates that the bearing assembly and diaphragm are cycling correctly.
3. If the screwdriver does not oscillate, poke the suction ball to ensure it is not stuck to the suction seat. If the screwdriver doesn't start oscillating, troubleshoot diaphragm (Page 19) and bearing assembly. Otherwise spray light weight oil in the suction seat and onto the suction ball. Reattach suction hose and test unit.
4. If unit still fails to operate correctly, remove control head in according instructions on page 19.
5. Inspect suction ball for any cuts, scratches, chips, rust or other damage. Inspect bevel edge of suction seat for any damage.
6. Replace suction seat and/or suction ball as required. However, if the suction seat requires replacement it is generally preferable to change the entire control head under the exchange program.
7. Replace control head as instructed in Inspection and Replacement of Control Head.

INSPECTION AND REPLACEMENT OF DISCHARGE VALVE

See Figure 10

1. Unscrew the discharge valve ball stop (item 10), with spring (item 15) and ring seal (item 17) attached.
2. Inspect ball stop stem for uneven wear, rough surface or other damage.
3. Remove discharge ball (item 13). Inspect for any cut, scratches, chips, rust or other damage.
4. Use a 7/16" allen wrench to unscrew the discharge seat (item 9) from the pump head (item 2). Clean seat and inspect bevel edge for damage. Also ensure that the seal on the underside of the seat is intact.
5. If no obvious damage to the discharge ball and seat, place ball into seat and fill with water. If water leaks out between ball and seat, they must be replaced.
6. Replace discharge ball stop, ball and/or seat as required.
7. Clean and inspect pump head opening, where the discharge seat was installed.
8. Grease pump head opening and discharge valve ball stop shoulder with multipurpose grease.
9. Screw discharge seat into pump head and torque to 85 ft-lbs.
10. Drop discharge ball into discharge seat.
11. Place spring with small side onto discharge valve ball stop.
12. Put ring seal over discharge valve ball stop and screw ball stop into the pump head. Torque to 15 ft-lbs.

A repair kit is available that includes the discharge ball and seat as KIT-1-3100 and one that includes the discharge ball, seat and ball stop as KIT-2-3100.

PRESSURE CALIBRATION

DO NOT USE THIS PROCEDURE WITHOUT A TEST GAUGE!

1. Install a gun, flexible airless hose and glycerin filled test gauge onto unit.
2. Prime unit.
3. Turn the control valve knob fully clockwise (maximum pressure setting).
4. Read the gauge, it should be approximately 2500 PSI.
5. If maximum pressure is incorrect, remove the black plastic cap from the control valve knob. Insert a 3/16" allen wrench into the control valve knob set screw, turn clockwise to increase pressure and counter-clockwise to decrease pressure. Replace black plastic cap.
6. NEVER set the maximum pressure above 2500 PSI.

BEARING HOUSE & DIAPHRAGM ASS'Y

FIG. 11

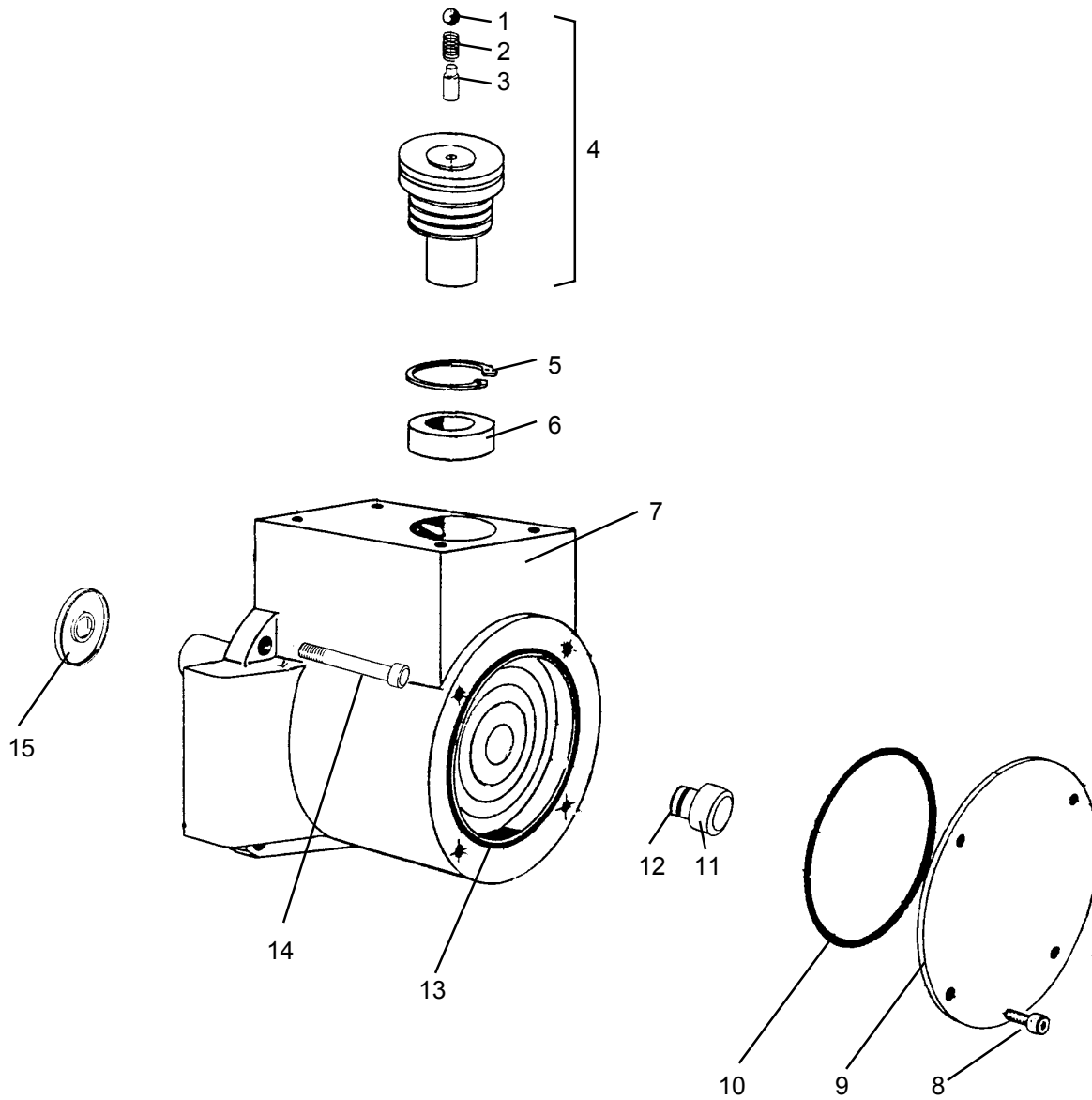

ITEM NO.	PART NO.	DESCRIPTION	ITEM NO.	PART NO.	DESCRIPTION
1	115-022	Suction Ball	9	112-007	Front Plate
2	115-025	Spring	10	112-021	O-Ring
3	114-010	Suction Ball Stop	11	112-052	Nylon Plug
4	114-001	Diaphragm (includes 2-3)	12	112-013	O-Ring
5	112-024	Snap Ring	13	139-070	Bearing Ass'y
6	112-006	Bronze Bushing	14	112-019	Screw (4)
7	112-003	Bearing Housing	15	139-039	Oil Seal
8	112-009	Screw (4)	16	139-071	Key (not shown)

REPLACEMENT OF OIL SEAL

See Figure 11.

1. With the Control Head removed, remove the four bolts (item 8), O-ring (item 10) and front plate (item 9), then drain the oil out of the bearing housing.
2. If the oil is contaminated, flush the bearing housing and assembly by pouring mineral spirits into the diaphragm hole and allowing it to drain out of the front of the bearing housing.
NOTE: Be sure to collect the old oil and mineral spirits and dispose of them in accordance with local regulations.
3. Remove nylon plug (item 11) and O-ring (item 12).
4. Remove snap ring (item 5) and bronze bushing (item 6) from the diaphragm hole of the bearing housing.
5. Unscrew the four bolts (item 14) attaching the bearing housing to the engine.
6. Pull bearing housing off of engine shaft. If it does not move freely, GENTLY tap bearing housing away from the engine with a rubber mallet. NEVER pry the engine and bearing housing apart.
7. If bearing housing still doesn't slide off the engine shaft, use a steering wheel puller to press the engine off the bearing housing.
8. Use seal puller, curved dental picks or similar tools to hook into the center of each side of the oil seal (item 15) and pull out the oil seal from the bearing housing. Be very careful not to score the inner and outer diameters of the bearing housing and assembly. Even a small scrape can prevent the new oil seal from sealing.
9. Place the new oil seal over the bearing assembly shaft with the spring towards the bearing housing.
10. Use a pipe with similar dimensions as the oil seal to slowly press the oil seal over the bearing assembly shaft and into the bearing housing, until the back of the seal is approximately 5/16" below the edge of the bearing housing. Do not press the oil seal beyond this point.
11. Place key into engine shaft keyway, with bevel side down and towards engine.
12. Start bearing assembly keyway onto key. Use breakable loctite and tighten the four bolts (item 14) so that the bearing assembly keyway slides completely over the key.
13. Replace snap ring and bronze bushing into bearing housing.
14. Insert nylon plug and O-ring into bearing assembly.
15. Replace O-ring, front plate and bolts onto bearing housing.
16. Pour 6 ounces of SAE 30 nondetergent oil (Part number 112-000) into bearing housing via the diaphragm hole.
17. Spin bearing assembly by rapidly pulling the engine pull rope, ensure that there is no binding.
18. Start engine at low RPM and slowly increase RPM to ensure proper bearing assembly movement.
19. Install diaphragm (See Page 19) and control head (See Page 19).

HANDLE ASSEMBLY ATTACHMENT

FIG. 12

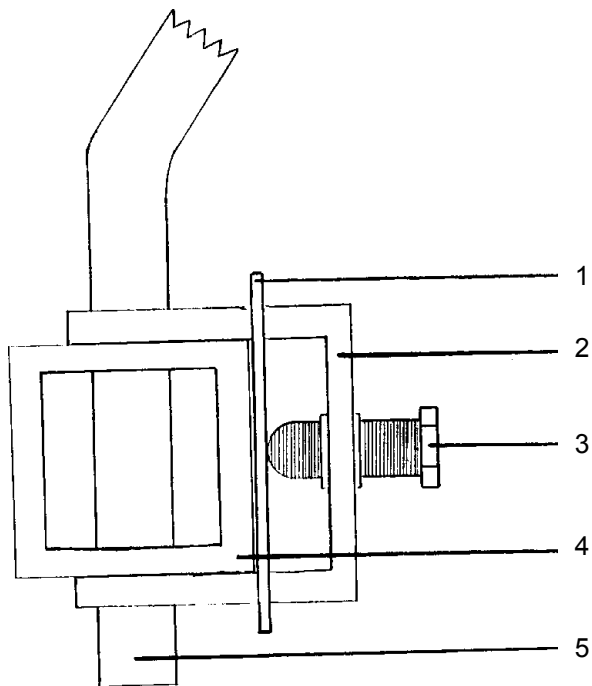

FIGURE 12 PARTS LIST

ITEM NO.	PART NO.	DESCRIPTION
1	305-108	Plate
2	305-051M	Clamp
3	100-370	Screw
4	139-339	Frame
5	139-356	Handle

GUN ARM ASSEMBLY ATTACHMENT

FIG. 13

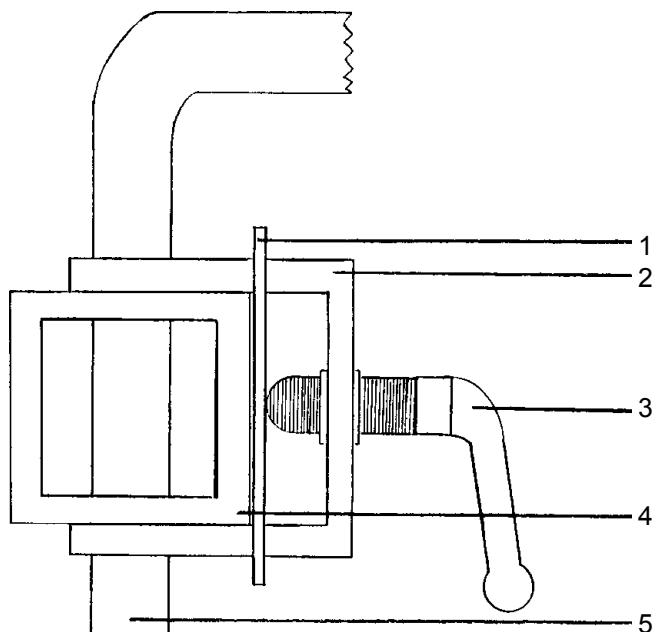

FIGURE 13 PARTS LIST

ITEM NO.	PART NO.	DESCRIPTION
1	305-108	Plate
2	305-051M	Clamp
3	305-044	Adjustable Handle
4	139-339	Frame
5	305-076	Gun Arm

GUN ASSEMBLY - PN 305-167

FIG. 14

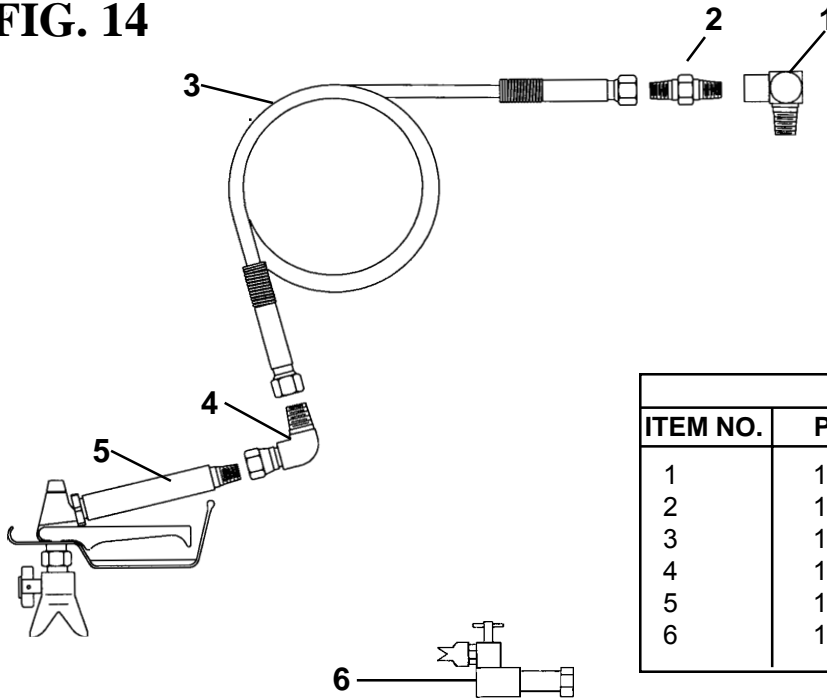

FIG. 14 PARTS LIST		
ITEM NO.	PART NO.	DESCRIPTION
1	100-004	Elbow
2	115-019	Hose Connector
3	100-011	Hose 1/4"x 50'
4	100-177	Swivel Elbow
5	120-001XL	Gun - 007XL
6	136-055	T Handle Ass'y

THROTTLE ASSEMBLY

FIG. 15

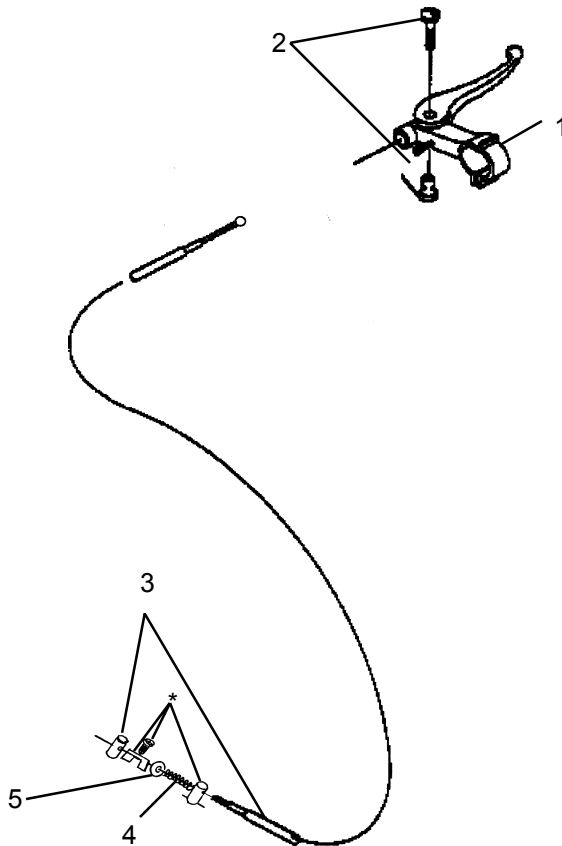
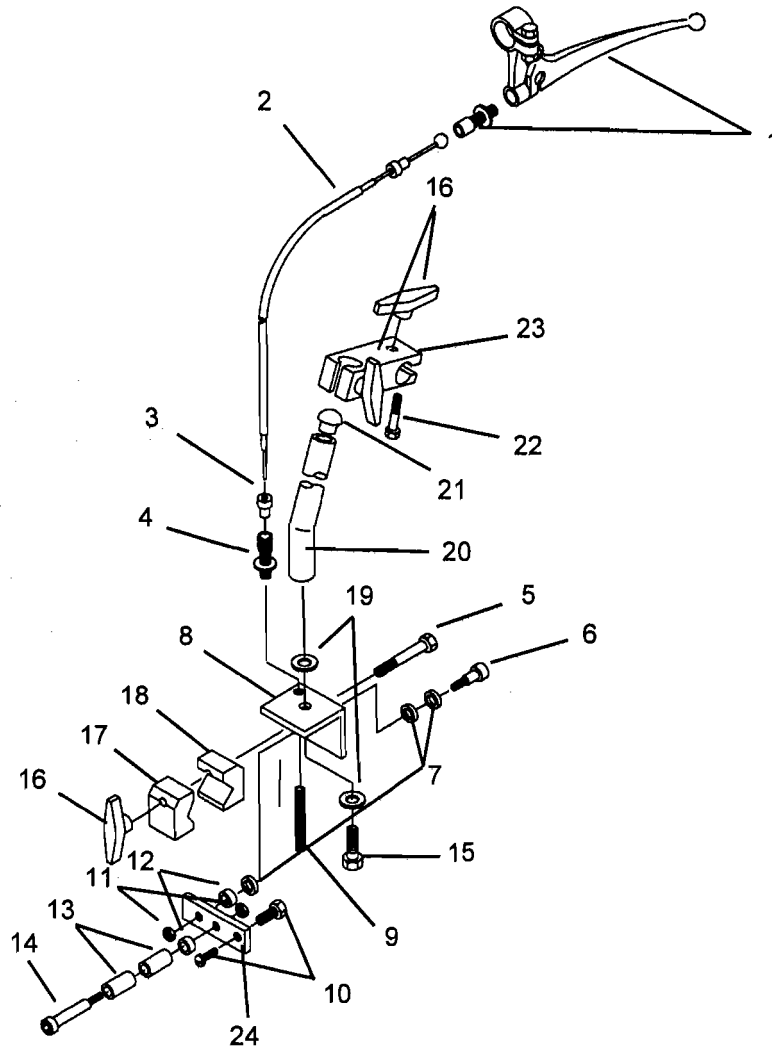

FIG. 15 PARTS LIST		
ITEM NO.	PART NO.	DESCRIPTION
1	305-105	Lever
2	136-023	Cable End Lug
3	305-092	Cable Ass'y
4	136-136	Spring
5	139-102	Washer
*		Part of Handle Engine Throttle Lever

GUN HOLDER ASSEMBLY(305 - 150)

FIG. 16



ITEM NO.	PART NO.	DESCRIPTION	ITEM NO.	PART NO.	DESCRIPTION
1	305-142	Lever Assembly	13	305-159	Sleeve Bearing (2)
2	305-077	Cable Assembly - Gun	14	305-160	Shoulder Screw
3	305-089	Cable Insert	15	169-050	Screw
4	305-141	Cable Adjuster	16	305-157	Knob (3)
5	100-321	Screw	17	305-152	Clamp - outer
6	305-158	Shoulder Screw	18	305-151	Clamp - inner
7	305-156	Thrust Washer (2)	19	113-027	Lock Washer (2)
8	305-154	Bracket	20	305-153	Tube - Gun Holder
9	116-100	Spring	21	143-027	Ball Guide
10	305-079	Wire Swivel Assembly	22	188-125	Screw (2)
11	140-045	Jam Nut (2)	23	136-019	Swivel Clamp Assembly
12	305-161	Spacer (2)	24	305-155	Lever

FRAME ASSEMBLY

FIG. 17

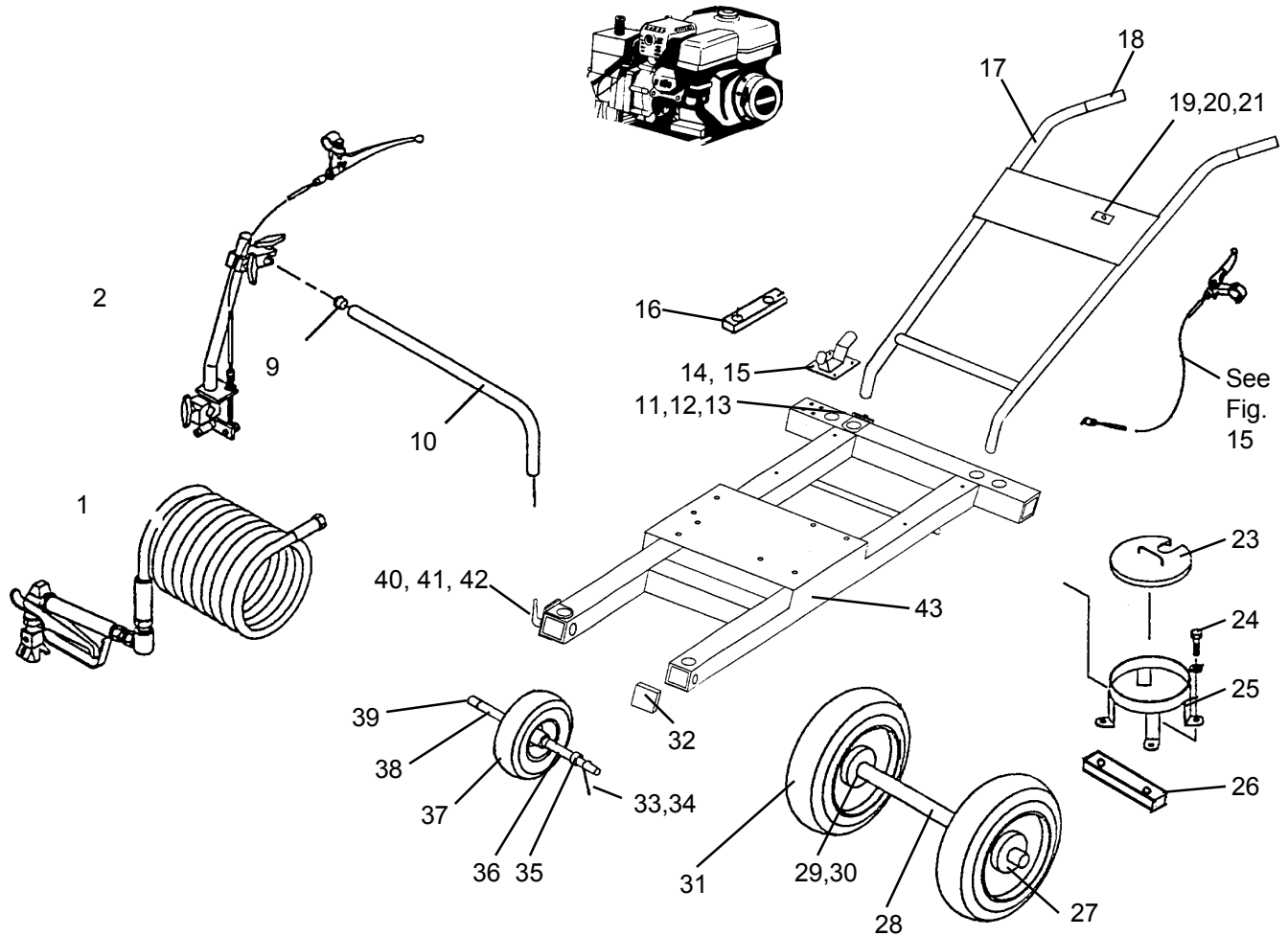

ITEM NO.	PART NO.	DESCRIPTION	ITEM NO.	PART NO.	DESCRIPTION
1	305-167	Gun Ass'y	23	301-533	Lid
2	305-150	Gun Holder Ass'y	24	119-026	Screw (4)
3	305-065	Paint system Ass'y	25	305-126	Bucket Holder
4	173-005	Screw (2)	26	305-143	Mounting Block (2)
5	136-123	Screw (3)	27	143-029	Set Collar (2)
6	136-197	Terminal Ring	28	301-170	Axle
7	301-530	Power Unit	29	112-058	Flanged Bearing (2)
8	301-517	Suction Hose Ass'y	30	100-369	Wave Washer (2)
9	143-027	Ball Guide	31	301-165	Wheel (2)
10	305-076	Arm	32	100-621	Cap (4)
11	305-108	Plate (2)	33	136-131	Chain
12	305-051M	Clamp (2)	34	136-133	Key Ring
13	100-370	Screw (2)	35	143-029	Set Collar (2)
14	305-185	Brake Ass'y	36	163-013	Spacer 2.75
15	100-373	Screw (4)	37	301-073	Wheel
16	301-535	Rubber Pad (2)	38	112-059	Spacer 4" (2)
17	139-536	Handle	39	113-032	Axle
18	305-058	Rubber Grip (2)	40	305-108	Plate
19	305-138	Cord Clamp (2)	41	305-051M	Clamp
20	331-342	Screw (2)	42	305-044	Adjustable Handle
21	120-021	Nut (2)	43	139-339	Frame

SUCTION ASSEMBLY - PART NO. 331-227

FIG. 18

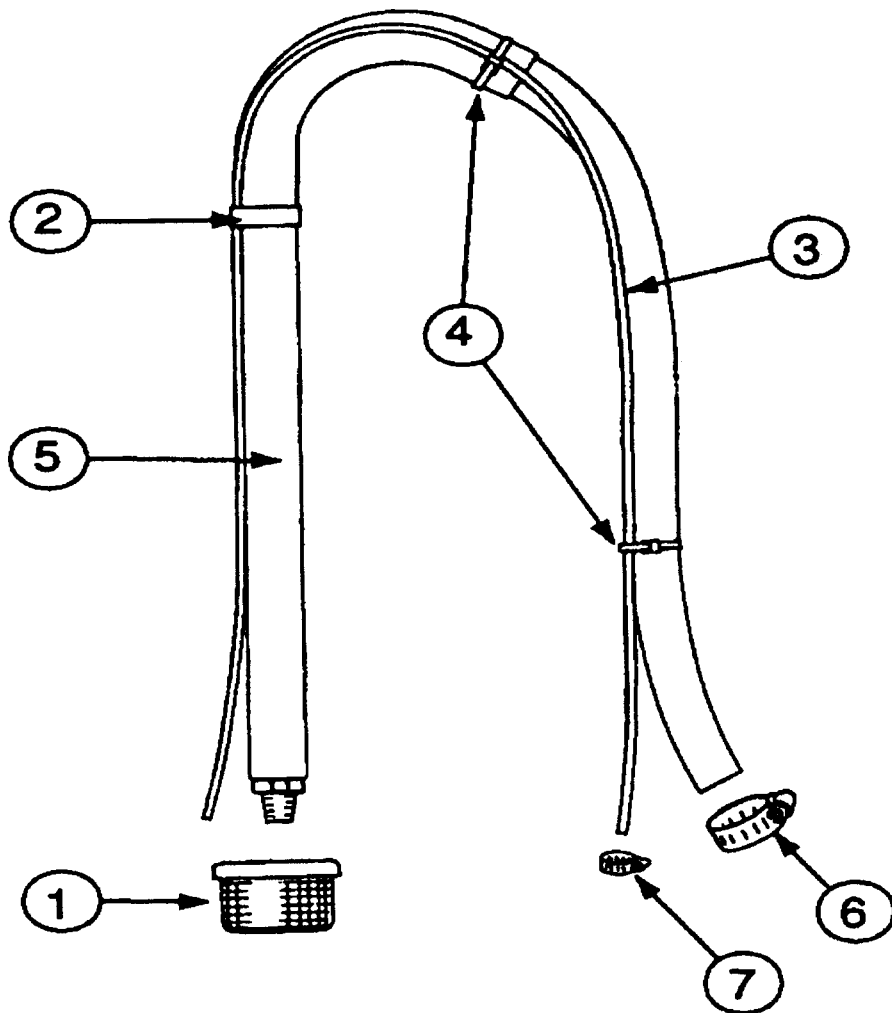

FIG. 18 PARTS LIST		
ITEM NO.	PART NO.	DESCRIPTION
1	331-217	Filter 16 mesh
2	331-135	Spring Clamp
3	331-137	Prime Hose (38")
4	111-016	Nylon Strap (2)
5	331-226	Suction Hose Ass'y
6	111-015M	Hose Clamp
7	141-015	Hose Clamp