



SPRAY & STRIPE 3000 SERVICE/OPERATION MANUAL



Spray
&
Stripe
3000

Table of Contents

INTRODUCTION

Spray & Stripe Specifications	1
Safety Warnings	2

GETTING STARTED

How to Flush	7
Flushing	8
Setting Up	9
Pressure Relief Procedure	10
Daily Maintenance	10
Starting Up	11
Striping Operation	12
Striping Spray Tip Guide	13

REPAIRS/MAINTENANCE INSTRUCTIONS

Spray Gun Operation	14
Spray Gun Troubleshooting	15
Field Troubleshooting	16
Servicing the Fluid Pump	17
Servicing the Piston Rod	18
Servicing the Suction Assembly	18
Packing Replacement	19
Inspection & Replacement of Control Valve, Ball & Seat	21
Pressure Control Calibration	21

PRODUCT DIAGRAMS & PARTS LISTS

Gearbox Assembly	22
Spray Gun Assembly	23
Gun Mount Assembly	23
Bypass Valve Assembly	24
Suction Assembly	25
Accessories	26

Manufactured by: AIRLESSCO BY DUROTECH CO.

5397 Commerce Ave. Moorpark, CA 93021

Tel: 805-523-0211 Fax: 805-523-1063

www.airlessco.com email: techsupport@airlessco.com

SUBJECT TO CHANGE WITHOUT NOTICE.

Copyright © 2005. All rights reserved.



Introduction

INTRODUCTION

The Spray & Stripe 3000 is a mobile airless sprayer designed to be used and strong enough to stripe parking lots yet light on it's wide tires to stripe sports fields. Plus it's based on a contractor quality paint spray pump so the gun can be snapped out of its holder and can be used as a mobile airless painting system for general exterior painting.

Built on a compact, well balanced frame, with "No Tools" removable handlebars, the 3000 features a dependable Durotech commercial 4-cycle engine with ball bearing supported crankshaft, automatic shutdown for low oil level, and our industry leading 5-year limited replacement warranty.

The paint delivery system is based on the proven durability of our LP "Slow-Stroking" stainless steel piston paint pump. This pump is used worldwide by thousands of commercial painters every day.

Forget about striper that lack the power to spray pure paint. The 3000 is **H₂NO READY!** No need to figure out how much water to add to the paint to properly atomize at the preset pressure designed into the sprayer. You simply just adjust the 3000's pressure control knob for optimal atomization of pure paint, or create the water/paint mix that you want to spray or stripe with.



Model 3000 Specifications:

Part #	300-225
Max Pressure	0 2500 PSI (170 Bar)
Max Output	.82 GPM (2.35 Litres/min.)
Max Tip	1 gun @ 0.027 inch 1 x 12" (30cm) line
Engine	DE400 Durotech, 4HP gasoline
Annual Galonage	500 gallons

IMPORTANT WARNING !!

HANDLE THIS UNIT AS YOU WOULD A LOADED FIREARM!!
High pressure spray can cause extremely serious injury.
OBSERVE ALL WARNINGS!

Before operating this unit, read and follow all safety warnings and instructions related to the usage of this equipment. READ, LEARN, and FOLLOW the Pressure Relief Procedure on Page 10 and understand all warnings on pages 2 thru 6.

All Service Procedures to be performed by an Authorized Airlessco Service Center ONLY. NO MODIFICATIONS or alterations of any Airlessco Equipment or part is allowed.

Safety Warnings

TOXIC FLUID HAZARD

Hazardous fluid or toxic fumes can cause serious injury or death if splashed in eyes or on skin, inhaled or swallowed. Know the hazards of the fluid you are using. Store & dispose of hazardous fluids according to manufacturer, local, state & national guidelines. ALWAYS wear protective eye wear, gloves, clothing and respirator as recommended by fluid manufacturer.

ALWAYS INSPECT SPRAYING AREA

- ALWAYS keep spraying area free from obstructions.
- ALWAYS make sure area has good ventilation to safely remove vapors and mists.
- NEVER keep flammable material in spraying area.
- NEVER spray in vicinity of open flame or other sources of ignition.

SPRAY GUN SAFETY

- ALWAYS set safety lock on the gun in "LOCKED" position when not in use and before servicing or cleaning.
- NEVER remove or modify any part of the gun.
- ALWAYS REMOVE SPRAY TIP when cleaning. Flush unit with LOWEST POSSIBLE PRESSURE.
- ALWAYS check operation of all gun safety devices before each use.
- Be very careful when removing the spray tip or hose from gun. A plugged line contains fluid under pressure. If the tip or line is plugged, follow the PRESSURE RELIEF PROCEDURE as outlined on page 10.

TIP GUARD

ALWAYS have the tip guard in place on the spray gun while spraying. The tip guard alerts you to the injection hazard and helps prevent accidentally placing your fingers or any part of your body close to the spray tip.

SPRAY TIP SAFETY

Use extreme caution when cleaning or changing spray tips. If the spray tip clogs while spraying, engage the gun safety latch immediately.

- ALWAYS follow the PRESSURE RELIEF PROCEDURE and then remove the spray tip to clean it.
- NEVER wipe off build up around the spray tip.
- ALWAYS remove tip & tip guard to clean AFTER pump is turned off and the pressure is relieved by following the PRESSURE RELIEF PROCEDURE.

KEEP CLEAR OF MOVING PARTS

Keep clear of moving parts when starting or operating the sprayer. Do not put your fingers into any openings to avoid amputation by moving parts or burns from hot parts.

Precaution is the best insurance against an accident.

When starting the engine, maintain a safe distance from moving parts of the equipment.

Before adjusting or servicing any mechanical part of the sprayer, follow the PRESSURE RELIEF PROCEDURE, and remove the ignition cable from the spark plug to prevent accidental starting of the sprayer.

LABELING

Keep all labels on the unit clean and readable. Replacement labels are available from the manufacturer.

Safety Warnings

**HIGH PRESSURE SPRAY CAN CAUSE EXTREMELY SERIOUS INJURY.
OBSERVE ALL WARNINGS.**

INJECTION HAZARD

Fluids under high pressure from spray or leaks can penetrate the skin and cause extremely serious injury, including the need for amputation.

- **NEVER** point the spray gun at anyone or any part of the body.
- **NEVER** put hands or fingers over the spray tip. Do not use a rag or any other material over your fingers. Paint will penetrate through material and into the hand.
- **NEVER** try to stop or deflect leaks with your hand or body.
- **NEVER** try to "blow back" paint, this is not an air spray sprayer.
- **ALWAYS** have gun tip guard in place when spraying.
- **ALWAYS** lock gun trigger when you stop spraying.
- **ALWAYS** remove tip from the gun to clean it.
- **ALWAYS** follow the **PRESSURE RELIEF PROCEDURE**, as shown on page 10, before cleaning or removing the spray tip or servicing any system equipment.
- **ALWAYS** Be sure equipment safety devices are operating properly before each use.
- **ALWAYS** tighten all fluid connections before each use.

MEDICAL TREATMENT

*If any fluid appears to penetrate your skin, get **EMERGENCY CARE AT ONCE. DO NOT TREAT AS A SIMPLE CUT.***

- * Go to an emergency room immediately.
- * Tell the doctor you suspect an injection injury.
- * Tell him what kind of material you were spraying with and have him read **NOTE TO PHYSICIAN**

MEDICAL ALERT - Airless Spray Wounds

*If any fluid appears to penetrate your skin, get **EMERGENCY MEDICAL CARE AT ONCE. DO NOT TREAT AS A SIMPLE CUT.** Tell the doctor exactly what fluid was injected. Have him read the following "NOTE TO PHYSICIAN"*

NOTE TO PHYSICIAN:

*Injection in the skin is a traumatic injury. It is important to treat the injury surgically as soon as possible. **DO NOT DELAY** treatment to research toxicity. Toxicity is a concern with some exotic coatings injected directly into the bloodstream. Consultation with a plastic surgeon or reconstructive hand surgeon may be advisable.*

GENERAL PRECAUTIONS

- **NEVER** alter equipment in any manner.
- **NEVER** spray highly flammable materials.
- **NEVER** allow another person to use sprayer unless they are thoroughly instructed on safety use and given this operators manual to read.
- **ALWAYS** wear a spray mask, gloves and protective eye wear while spraying.
- **ALWAYS** ensure fire extinguishing equipment is readily available and properly maintained.
- **NEVER** smoke while in spraying area.
- **NEVER** use around children.

**NEVER LEAVE SPRAYER UNATTENDED WITH PRESSURE IN THE SYSTEM.
FOLLOW PRESSURE RELIEF PROCEDURES ON PAGE 10.**

Safety Warnings

GROUNDING

Ground the sprayer and other components in the system to reduce the risk of static sparking, fire or explosion which can result in serious bodily injury and property damage.

Always ground all of these components:

- **Fluid Hose:** use only grounded hoses.
- **Spray gun or dispensing valve:** grounding is obtained through connection to a properly grounded fluid hose and pump.
- **Object being sprayed:** according to your local code.
- All solvent pails used when flushing should only be metal pails which are conductive.

Once each week, check electrical resistance of hose (when using multiple hose assemblies, check overall resistance of un-pressurized hose must not exceed 29 megohms (max) for any coupled length or combination of hose lengths. If hose exceeds these limits, replace it immediately.

Never exceed 300 Ft. (150 m.) overall combined hose length to assure electrical continuity.

AVOID COMPONENT RUPTURE

This sprayer operates at 2500 psi (170 bar). Always be sure that all components and accessories have a maximum working pressure of at least 3000 psi to avoid rupture which can result in serious bodily injury including injection and property damage.

- **NEVER** leave a pressurized sprayer unattended to avoid accidental operation of it which could result in serious bodily injury.
- **ALWAYS** follow the PRESSURE RELIEF PROCEDURE whenever you stop spraying and before adjusting, removing or repairing any part of the sprayer.
- **NEVER** alter or modify any part of the equipment to avoid possible component rupture which could result in serious bodily injury and property damage.
- **NEVER** use weak, damaged or non-conductive paint hoses. Do not allow kinking or crushing of hoses or allow it to vibrate against rough, sharp or hot surfaces. Before each use, check hoses for damage and wear and ensure all fluid connections are secure.
- **REPLACE** any damaged hose. NEVER use tape or any device to mend the hose.
- **NEVER** attempt to stop any leakage in the line or fittings with your hand or any part of the body. Turn off the unit and release pressure by following PRESSURE RELIEF PROCEDURE on page 10.
- **ALWAYS** use approved high pressure fittings and replacement parts.
- **ALWAYS** ensure fire extinguishing equipment is readily available and properly maintained.

WARNING

Do not use halogenated solvents in this system. The prime valve, 2 gun manifold and most airless guns have aluminum parts and may explode. Cleaning agents, coatings, paints or adhesives may contain halogenated hydrocarbon solvents. DON'T TAKE CHANCES! Consult your material suppliers to be sure. Some of the most common of these solvents are: Carbontetrachloride, Chlorobenzene, Dichloroethane, Dichloroethyl Ether, Ethylbromide, Ethylchloride, Tetrachloethane. Alternate valves and guns are available if you need to use these solvents.

Safety Warnings

FLUSHING

Reduce risk of injection injury, static sparking or splashing by following the specific cleaning procedure on page 7.

- **ALWAYS** follow the PRESSURE RELIEF PROCEDURE on page 10.
- **ALWAYS** remove the spray tip before flushing. Hold a metal part of the gun firmly to the side of a metal pail and use the lowest possible fluid pressure during flushing.
- **NEVER** use cleaning solvents with flash points below 140° F. Some of these are: acetone, benzene, ether, gasoline and naphtha. Consult your supplier to be sure.
- **NEVER** smoke in the spraying/cleaning area.

PREVENT STATIC SPARKING FIRE/ EXPLOSIONS

ALWAYS be sure all equipment and objects being sprayed are properly grounded. Always ground sprayer, paint bucket and object being sprayed. See "grounding" on page 4 for detailed grounding information.

Vapors created when spraying can be ignited by sparks. To reduce the risk of fire, do not plug in or unplug any electrical cords in an enclosed spray area. This can create sparks when there is any chance of igniting vapors still in the air. Follow the coating & solvent manufacturers safety warnings and precautions.

Use only conductive fluid hoses for airless applications. Be sure gun is grounded through hose connections. Check ground continuity in hose & equipment. Overall (end to end) resistance of un-pressurized hose must not exceed 29 megohms for any coupled length or combination of hose length. Use only high pressure airless hoses with static wire approved for 3000 psi.

Important: United States Government safety standards have been adopted under the Occupational Safety & Health Act. These standards, particularly the General Standards, Part 1910, & the Construction Standards, part 1926 should be consulted.

WHEN SPRAYING & CLEANING WITH FLAMMABLE PAINTS OR PAINT THINNERS:

1. When spraying with flammable liquids, unit must be located a minimum of 25 feet away from spraying area in a well ventilated area. Ventilation must be sufficient enough to prevent the accumulation of vapors.
2. To eliminate electrostatic discharge, ground the spray unit, paint bucket and spraying object. Use only high pressure airless hoses approved for 3000 psi which is conductive.
3. Remove spray tip before cleaning gun and hose. Make contact of gun with bucket and spray without the tip in a well ventilated area, into the grounded steel bucket.
4. Never use high pressure in the cleaning process. USE MINIMUM PRESSURE.
5. Do not smoke in spraying/cleaning area.

GAS ENGINE PRECAUTIONS

WHEN ADDING FUEL

- Turn engine OFF and let engine cool at least 2 minutes before removing gas cap.
- Fill fuel tank outdoors or in well ventilated area.
- Do not overfill fuel tank. Fill tank to approximately 1/2 inches below top of neck to allow for fuel expansion.
- Keep gasoline away from sparks, open flames, pilot lights, heat and other ignition sources.
- Check fuel lines, tank, cap and fittings frequently for cracks or leaks. Replace if necessary.

WARNING

Gasoline & its vapors are extremely flammable & explosive.

Fire or explosion can cause severe burns or death.

WHEN STARTING ENGINE

- Make sure spark plug, muffler, fuel cap and air cleaner are in place. Do not attempt starting without spark plug!
- Make sure oil level is to the full mark. *Engine will not run should oil level drop below a safe level.*
- If fuel spills, wait until it evaporates before starting engine.
- If engine floods, set choke to OPEN/RUN position, place throttle in FAST and crank until engine starts.

WHEN OPERATING EQUIPMENT

- Do not tip engine or equipment at angle which causes gasoline to spill.

Safety Warnings

WHEN TRANSPORTING EQUIPMENT

- Transport with fuel tank **EMPTY** or with fuel shut-off valve **OFF**.

WHEN STORING GASOLINE OR EQUIPMENT WITH FUEL IN TANK

- Store away from furnaces, stoves, water heaters and other appliances that have pilot lights or other ignition source. They can ignite gasoline vapors.

WARNING

**Starting engine creates sparking.
Sparking can ignite nearby flammable gases.
Explosion and fire could result.**

- If there is natural or LP gas leakage in area, do not start engine.
- Do not use pressurized starting fluids because vapors are flammable.

WARNING

**Rapid retraction of starter cord (kickback) will pull hand and arm toward engine faster than you can let go.
Broken bones, fractures, bruises or sprains could result.**

- When starting engine, pull cord slowly until resistance is felt, then pull rapidly.
- Remove all external equipment/engine loads before starting engine.
- Direct coupled equipment components such as, but not limited to, blades, impellers, pulleys, sprockets, etc. must be securely attached.

WARNING

**Rotating parts can contact or entangle hands, feet, hair, clothing or accessories.
Traumatic amputation or severe laceration can result.**

- Operate equipment with guards in place.
- Keep hands and feet away from rotating parts.
- Tie up long hair and remove jewelry.
- Do not wear loose fitting clothing, dangling drawstrings or items that could become caught.

WARNING

**Engines give off carbon monoxide, an odorless, colorless, poison gas.
Breathing carbon monoxide can cause nausea, fainting or death.**

- Start and run engine outdoors.
- Do not start or run engine in enclosed area, even if doors or windows are open.

WARNING

**Running engines produce heat. Engine parts, especially mufflers, become extremely hot.
Severe thermal burns can occur on contact.
Combustible debris, such as leaves, grass, brush, etc. can catch fire.**

- Allow muffler, engine cylinder and fins to cool before touching.
- Remove accumulated combustibles from muffler area and cylinder area.
- Install and maintain in working order a spark arrester before using equipment on forest covered, grass covered and brush covered unimproved land. The state of California requires this (Section 4442 of the California Public Resources Code). Other states may have similar laws. Federal laws apply on federal land.

WARNING

**Unintentional sparking can result in fire or electric shock.
Unintentional start up can result in entanglement, traumatic amputation, or lacerations.**

BEFORE PERFORMING ADJUSTMENTS OR REPAIRS

- Disconnect spark plug wire and keep it away from spark plug.
- Disconnect battery at negative terminal (only engines with electric start).

WHEN TESTING FOR SPARK

- Use approved spark plug tester.
- Do not check for spark with spark plug removal.

How to Flush

FIGURE 1

LOCK TRIGGER TO REMOVE SPRAY TIP



FIGURE 2

CONTROL VALVE



1. Be sure the gun safety latch is engaged and there is no spray tip in the gun. Refer to Fig. 1. Refer to your separate instruction manual provided with your gun on its safety features and how to engage safety latch.
2. Pour enough clean, compatible solvent (or water when using water-base paint) into a large, empty metal pail to fill the pump and hoses.
3. Place the suction tube into the pail.
4. Turn the control valve to the prime position or fully counterclockwise. Refer to Fig. 2.
5. Move the throttle lever slightly to the FAST position, using the handlebar mounting throttle lever.
6. Move the choke control lever to the CHOKE position. Refer to Fig. 3.
7. Turn the stop switch to ON. Pull the start rope. Pull the engine over against compression stroke and then let the rope rewind slowly into the starter. Pull firmly and rapidly to start the engine. Do NOT drop the rope. Hold onto the handle while rewinding, or rope may rewind improperly and jam the assembly. If the engine does not start, open the choke half way. If the engine floods, open the choke all the way and continue cranking.
8. After the engine is warm, gradually open the choke lever, increase the RPM of engine by squeezing the throttle control trigger on the handlebars.

WARNING

To reduce the risk of static sparking, which can cause fire or explosion, always hold a metal part of the gun firmly against the metal pail when flushing. This also reduces splashing. Refer to Fig. 4.

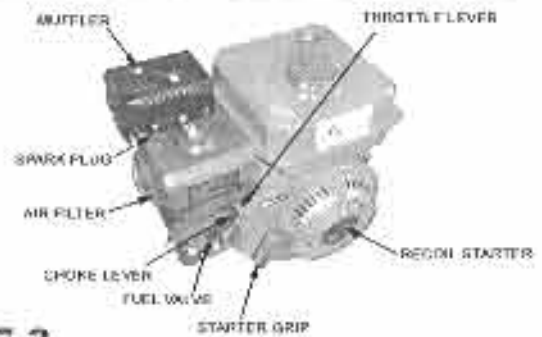

FIGURE 3

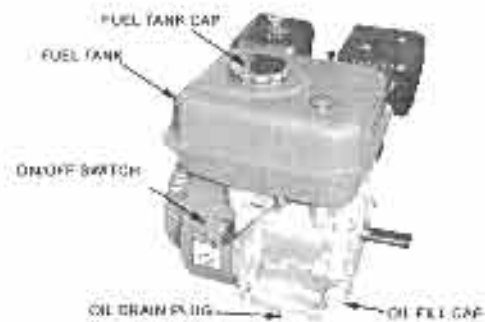

FIGURE 4

Maintain firm metal to metal contact between gun and container.



9. Point the gun into the metal pail and hold a metal part of the gun firmly against the pail. Refer to Fig. 4.
10. Disengage the gun safety latch and squeeze the gun trigger. Turn the control valve clockwise just enough to move liquid at low pressure.
11. Allow the pump to operate until clean solvent comes from the gun.
12. Release the trigger and engage the gun safety latch.
13. If you are going to start spraying, place the pump or suction tube into the supply container. Release the gun safety latch and trigger the gun into another empty, metal container, holding a metal part of the gun firmly against the metal pail (Fig. 4) and force the solvent from the pump and hose. When paint starts coming from the gun, turn control valve to prime or fully counter clockwise position and engage the gun safety latch.
14. If you are going to store the sprayer, remove the suction tube or pump from the solvent pail, force the solvent from the pump and hose. Engage the gun safety latch and refer to the "Storage" Procedure on page 8.
15. Whenever you shut off the sprayer, follow the Pressure Relief Procedure warning on page 10.

Flushing

Read prior to using your sprayer

1. New Sprayer

Your Airlessco unit was factory tested in an antifreeze solution which was left in the pump. Before using oil-base paint, flush with mineral spirits only. Before using water-base paint flush with soapy water, then do a clean water flush.

2. Changing Colors

Flush with a compatible solvent such as mineral spirits or water.

3. Changing from Water-Base to Oil-Base Paint

Flush with soapy water, then mineral spirits.

4. Changing from Oil-Base to Water-Base Paint

Flush with mineral spirits, followed by soapy water, then do a clean water flush.

5. Storage

Oil-base paint: Flush with mineral spirits.

Water-base paint: Flush with water, then mineral spirits and leave the pump, hose and gun filled with mineral spirits. For longer storage, use mixture of mineral spirits and motor oil (half & half). Shut off the sprayer, follow Pressure Relief Procedure on page 10

Setting Up to Stripe or Spray

1. Connect the hose and gun.

- If the hose is not already installed on the striper, remove the plastic cap plug from the outlet tee at the spray pump, and screw a conductive or grounded 3000 psi airless spray hose onto fluid outlet.
- Connect an airless spray gun to the other end of the hose.
- Do not use steel braided airless hose. Use nylon braided airless hose only.

NOTE: Do not use thread sealer on swivel unions as they are made to self-seal. Use thread seal on tapered male threads only.

2. Remove the snap-on cover plate over the piston.



3. Fill the packing nut/wet cup with 5 drops of Airlessco Throat Seal Oil (TSO) and then reinstall snap-on piston cover plate.

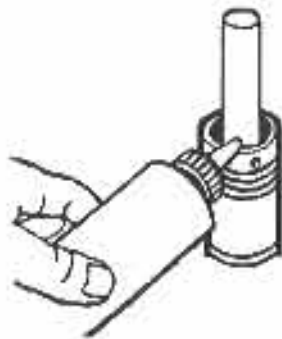

Failure to lubricate the piston properly with throat seal oil can cause premature wear and damage to piston and packings.



3. Grounding

WARNING

To reduce the risk of static sparking, fire or explosion which can result in serious bodily injury and property damage, always ground the sprayer and system components and the object being sprayed, as instructed in the safety warning section of this manual.

A small steel chain grounding strap is installed at the factory to prevent static build-up.

4. Flush the sprayer

As per "Flushing Procedure" in this manual

Pressure Relief Procedure

To avoid possible serious bodily injury, including injection, always follow this procedure whenever the sprayer is shut off, when checking or servicing it, when installing or changing the tips, whenever you stop spraying or when you are instructed to relieve the pressure.

1. Engage gun safety latch. Refer to instruction manual provided with your gun on its safety features and how to engage safety latch.

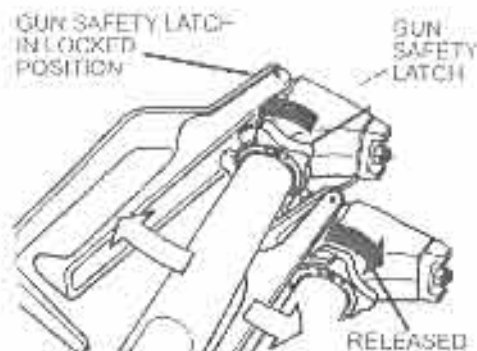

2. Turn engine off using OFF switch on the engine.

3. Disengage safety latch & trigger gun to relieve residual fluid pressure. Hold metal part of the gun in contact with grounded metal pail.



4. Re-engage gun safety latch.

5. Turn Control Valve (Prime/Pressure Relief Valve) as shown open (priming) to relieve fluid pressure.



Daily Maintenance

1. Keep the displacement pump packing nut/wet cup lubricated with Airlessco TSO (Throat Seal Oil) at all times. The TSO helps protect the rod and the packings.
2. Inspect the packing nut daily. Your pump has a patented Triple-Life Packing System. *Packing life will be extended a minimum of three times if the following "Packing Adjustment" procedure is followed monthly:*

If seepage of paint into the packing nut and/or movement of the piston upward is found (while not spraying), the packing nut should be tightened enough to stop leakage only, but not any tighter. Overtightening will damage the packings and reduce the packing life.

3. Tighten suction nut daily.

Starting Up

1. Learn how to operate the control valve.

The control valve sets the prime or pressure position as well as the spraying pressure. When the valve is fully counter-clockwise the unit is in the prime position. As the control valve is turned clockwise, the unit's output pressure to the gun is gradually increased until the control valve is fully clockwise and the unit is at its maximum output pressure of 2500 psi. This will fully atomize any stain or paint without needing to dilute the material.



FOLLOW "PRESSURE RELIEF PROCEDURES" ON PAGE 10 WHENEVER YOU:

- are instructed to relieve pressure
- stop spraying
- checking or servicing any of the system equipment.
- install or clean the spray tip.

WARNING

To stop the unit in an emergency or before performing any service or maintenance procedure follow the Pressure Relief Procedure on page 10 to relieve the fluid pressure.

HANDLE THE SPRAY SYSTEM AS YOU WOULD A LOADED FIREARM!!

2. Prepare the Material

- Prepare the material according to the manufacturer's material recommendations.
- Place the suction tube into the material container.

3. Starting the Sprayer

Refer to Figure above for steps a - c

- Pressure Control Knob must be in the low pressure position.
- Control Valve must be open to the priming position or fully counterclockwise.

Refer to Fig 3 Page 7 for steps e - h.

- Move the choke to the closed position.
- Move the throttle lever slightly to the FAST position.
- Turn fuel valve ON (Honda only). Pull the start rope. Pull engine over against compression stroke & let the rope rewind slowly into the starter. Pull firmly & rapidly to start engine. Do NOT drop the rope. Hold onto handle while rewinding or the rope may rewind improperly & jam the assembly. If the engine does not start, open the choke half way. If engine floods, open the choke all the way & continue cranking.
- After the engine is warm, gradually open the choke lever, increase the RPM of engine by squeezing the throttle control trigger on the handlebars.

- Disengage gun safety latch & squeeze gun trigger. Turn control valve clockwise just enough to move liquid at low pressure.
- Allow the pump to operate until clean solvent comes from the gun.
- Install spray tip onto gun.
- If so equipped, turn engine switch to ON position, then pull starter rope vigorously until engine starts.
- Turn Control Valve clockwise to the desired spray pressure required to properly atomize your material (Sprayer is limited to a maximum of 2500 psi).
- Disengage the gun safety lock and you are ready to start spraying.

WARNING

If you spray into the paint bucket, always use the lowest spray pressure and maintain firm metal to metal contact between gun and container.

5. Adjusting the Pressure

- Turn the Control Valve clockwise to increase pressure and counter clockwise to decrease pressure.
- Always use the lowest pressure and engine RPM necessary to completely atomize the material.
- If wider coverage is needed, use a larger tip rather than increasing the pressure.
- Check the spray pattern. The tip size and angle determines the pattern width and flow rate.
- A trigger locking button is provided on the engine speed and spray gun actuation levers to prevent hand cramping and user fatigue during extended stripping sessions.

CAUTION

Operating the sprayer at higher engine RPM or higher pressure than needed wastes material, causes early tip wear and shortens engine and sprayer pump life!

Striping Operation

1. Choose handle location

The choices are: installing the handle opposite of the single wheel assembly (standard set up) or placing the handle directly over the single wheel assembly. The handle location is really a matter of personal preference, however having the handle away from the single wheel assembly allows for easier loading/unloading from a van or truck.

2. Cable Tension Adjustment

Once the handle and gun arm assemblies are set up to the preferred positions, pressurize the unit and trigger the gun to ensure that it activates and releases correctly. If not, adjust the cable tension as follows:

- Locate the adjustment knobs on the base of the gun trigger, where the cable connects to the gun trigger assembly.
- Loose the locking nut & move the adjusting screw until the slack has been removed from the cable.
- Tighten locking nut and retest gun triggers for proper function.

Note: There is an additional cable adjustment where the cable attaches to the gun holder assembly. Use only if the gun trigger adjustment is insufficient.

3. Miscellaneous Operations

CURBS: To paint at a 90 degree angle to spray the sides of curbs install a swivel, part # 032-028, between gun head and tip guard and aim guard sideways towards the curb.

WIDE STRIPES: Install wider fan striping tips and raise the gun height to achieve the desired width line.

STENCILS: Install standard spray tip on the gun. Rotate gun to remove from the gun holder and use the gun to spray within your stencils. Use of an Airless X-TENDA-POLE extension pole (see ordering chart below) will make this job a lot easier on the operators back, and is highly recommended.

STANDARD PAINTING: Install the appropriate size and type of paint spraying tip (standard paint spray, "W" wide pattern, or "Fine Finish") Remove gun and spray just as you do for stencils. Additional paint hose may be required depending on the distance between the job and the equipment.

XTEND-A-POLE SYSTEM

Tip Extensions - Complete with Patented SPRAY CLEAN REV-GUARD



TIP EXTENSIONS, "G" THREAD

032-170	6" Long
032-171	12" Long
032-172	18" Long
032-173	24" Long

SWIVEL EXTENSION, "G" THREAD

032-184	36" Long
---------	----------

EXTENSIONS (BARE POLES)

Add Tip Extension or Swivel Extension to create desired length

032-053	24" Long
032-054	36" Long

Striping Tip Guide

Rev-Tip for Striping		STRIPING TIP - ORIFICE SIZE (inches)												
Fan Width (in from surface)		.009	.011	.013	.015	.017	.019	.021	.023	.025	.027	.031	.035	
1-2	25-51			113ST	115ST	117ST	119ST							
2-4	51-102				215ST	217ST	219ST	221ST						
4-6	102-152				315ST	317ST	319ST	321ST						
6-8	152-203													
Striping Paint				Oil Base	Oil Base	Latex	Latex	Latex	Latex	Latex	Latex			
Water Flow Rate (gpm) <small>(rate of 200 lbs. (30 bar)</small>	(lpm)	.12	.18	.24	.31	.38	.47	.57	.67	.77	1.03	1.31	1.63	1.80
Paint Flow Rate (gpm) <small>(rate of 200 lbs. (30 bar)</small>	(lpm)	.10	.15	.21	.27	.33	.40	.49	.58	.66	.88	1.12	1.39	1.54
Pump Minimum Output (gpm) <small>(rate of 200 lbs. (30 bar)</small>	(lpm)	.25	.25	.33	.40	.50	.60	.75	.88	1.0	1.25	1.5	2.0	2.2
Output (gpm) <small>(rate of 200 lbs. (30 bar)</small>		1.0	1.0	1.25	1.5	1.9	2.3	2.8	3.3	3.8	4.7	5.7	7.5	8.2

REV-TIP for Striping
P.N. 562-xxx5T
 Includes Rev-Tip™ Metal Seal
 & O-Ring Seal.

Sample:

1.2 Fan Width
560-215
 REV-TIP™ Orifice Size

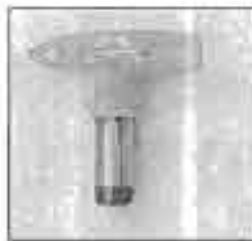

REV-GUARD
Super Compact
P.N. 561-001

11/16-16" F" Thread, Fits:
 Adhesco, and some ASM,
 Wagner, and Campbell Hausfeld.

P.N. 561-002

7/8-14" G" Thread,
 Fits some: Graco, Wagner,
 Titan Adhesco



Striping Tips should not be used for regular spraying. Striping tips are designed for a single pass application, while spray tips are designed for the 1/3 overlap technique used for spray painting.

Spray Tip Replacement: Dulling use high pressure will cause the orifice to grow larger. This destroys the flat spray pattern or will leave tailing or two heavy lines on the outside of the pattern. When this occurs replace the spray tip or excessive paint will be wasted.

REGULAR PAINTING SPRAY TIP

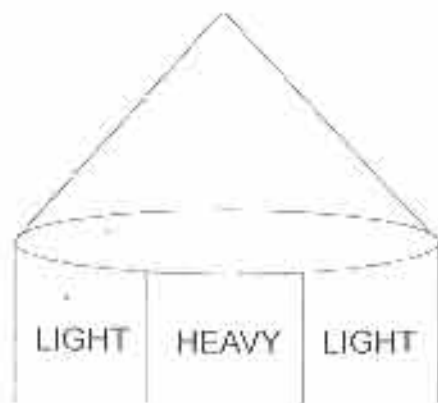

STRIPING TIP



UNIFORM PATTERN

Spray Gun Operation

SPRAY GUN

Attach spray gun to airless unit and tighten fittings securely. Set the gun safety latch. (Also may be called gun safety lock, or trigger lock)

* The gun safety latch should always be set when the gun is not being triggered.

Read all warnings and safety precautions supplied with the spray gun and in product manual.

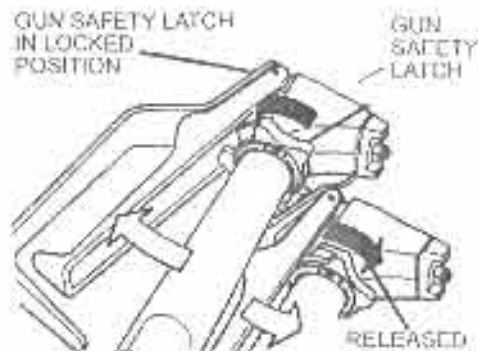

MAJOR COMPONENTS OF SPRAY GUN & REVERSIBLE REV-TIP™

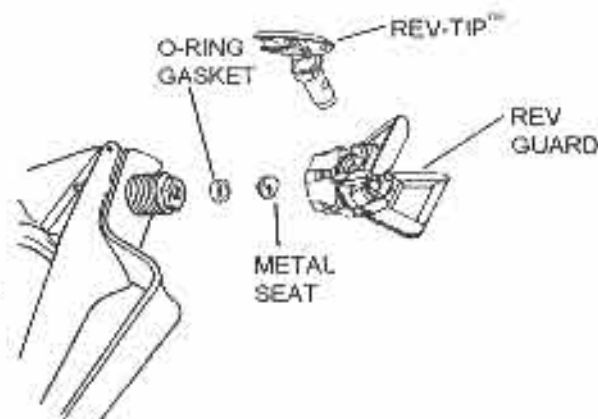
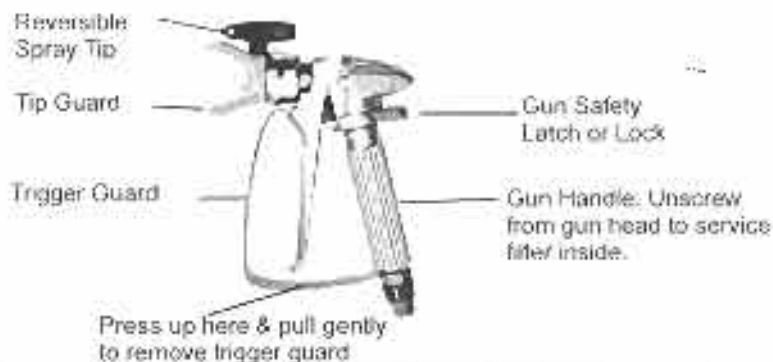

SPRAY TIP ASSEMBLY

1. Be sure the pressure relief procedure is followed before assembling tip and housing to the gun.
2. Insert REV-TIP™ cylinder into the REV-GUARD™ (guard housing assembly).
3. Guide the metal seat into REV-GUARD™ (guard housing assembly) through the retaining nut and turn until it seats against the cylinder.
4. Insert the O-Ring gasket onto the metal seat so that it fits into the grooves.
5. Finger tighten REV-GUARD™ retaining nut onto the gun.
6. Turn guard in the desired position.
7. Completely tighten the retaining nut.



TO REMOVE CLOGS FROM SPRAY TIP

1. Lock gun safety latch.
2. Turn REV-TIP™ handle 180 degrees.
3. Disengage trigger lock and trigger gun into the pail.
4. If the REV-TIP™ handle appears locked (resists turning), loosen the retaining nut. The handle will now turn easily.
5. Engage gun safety latch and return handle to the spray position.



CLEANING SPRAY GUN

Immediately after the work is finished, flush the gun out with a solvent. Brush pins with solvent and oil them lightly so they will not collect dried paint.

CLEANING FILTER IN GUN HANDLE

To clean the filter, use a brush dipped in an appropriate solvent. Change or clean filters at least once a day. Some types of latex may require a filter change after four hours of operation.

CLOGGED FLAT TIP

Should the spray tip become clogged, relieve pressure from hose by following the "Pressure Relief Procedure." Secure gun with the safety latch, take off guard, take out the tip, soak in appropriate solvent & clean with a brush. (Do not use a needle or sharp pointed instrument to clean the tip. The tungsten carbide is brittle and can chip.)

Spray Gun Troubleshooting

DEFECTS	CAUSE	CORRECTION
Coarse spray	Low pressure	Increase the pressure
Excessive fogging (overspray)	High pressure Material too thin	Reduce pressure for satisfactory pattern Use less thinner
Pattern too wide	Spray angle too large	Use smaller spray angle tip
Pattern too narrow	Spray angle too small	Use larger spray angle tip. (If coverage is OK, try tip in same nozzle group)
Too much material	Tip size too large Material too thin Pressure too high	Use next smaller tip Reduce pressure
Too little material	Tip size too small Material too thick	Use next larger tip
Thin distribution in center of pattern "horns"	Worn tip Wrong tip	Change for new tip Use tip with a smaller spray angle
Thick skin on work	Material too viscous Application too heavy	Thin material Reduce pressure and/or use smaller tip
Coating fails to close & smooth over	Material too viscous	Thin material
Spray pattern irregular, deflected	Orifice clogged Tip damaged	Clean carefully Replace with new tip
Craters or pock marks	Solvent balance	Use 1-3% "short" solvents remainder "long" solvents. (This is most likely to happen with material of low viscosity, lacquers etc.)
Bubbles on work	Contamination or dust	Clean surface to be sprayed
Clogged screens	Extraneous material in paint Coarse pigments Poorly milled pigments Paint pigments flocculate cover screen. Incompatible paint mixture & thinners.	Clean screen Use coarse screen if orifice size allows Use coarser screen, larger orifice tips. Obtain ball milled paint. If thinner was added, test to see if a drop on top of paint mixes or flattens out on the surface. If not, try different thinner in fresh batch of paint.

TEST THE PATTERN

Good, full



Spotty Pattern
Increase Pressure.



Field Troubleshooting

<u>PROBLEM</u>	<u>CAUSE</u>	<u>SOLUTION</u>
Unit doesn't prime	Airleak due to: <ul style="list-style-type: none"> • Loose Suction Nut • Worn O-Rings • Hole in Suction Hose Stuck or Fouled Balls	<ul style="list-style-type: none"> • Tighten Suction Nut • Replace O-Ring (106-011) on suction seat. & O-Ring (106-020) below suction seat • Replace Suction Hose (331-290) Service outlet valve suction assembly
Unit primes but has no or poor pressure	Pressure set too low Filter(s) are clogged Outlet Valve fouled/worn Prime/Pressure Relief valve bypassing Packings and/or piston worn	Turn up pressure Clean or replace gun filter, inlet filter and/or manifold filter Service outlet valve Clean or replace prime valve <ul style="list-style-type: none"> • Tighten packing nut • Repack unit
Unit does not maintain good spraying pressure	Blown spray tip Packings and/or piston worn Upper Seat worn	Replace spray tip Repack unit Replace upper seat

Servicing the Fluid Pump

Fluid Pump Disconnect

Refer to Figure 1

1. Follow the Pressure Relief Procedure on page 10.
2. Flush the material you are spraying out of the machine.
3. Remove the connecting rod shield (331-111).
4. Move the piston rod (331-093) to its lowest position by cycling pump slowly.
5. Remove the retaining ring (331-062) from the connecting rod (331-038) and slide the sleeve (331-117) down revealing the connecting rod pin (331-065).
6. Remove the suction tube assembly from the fluid pump (331-209) by unscrewing the suction nut (331-034) with the packing adjustment tool.
7. Using a 1/2" wrench unscrew the two bolts (100-318) from the cover assembly (331-537). The fluid pump (331-209) will be hanging loosely at this point.
8. Remove the connecting rod pin (331-065) out of the connecting rod (331-038), allowing the removal of the fluid pump (331-209) from the machine.

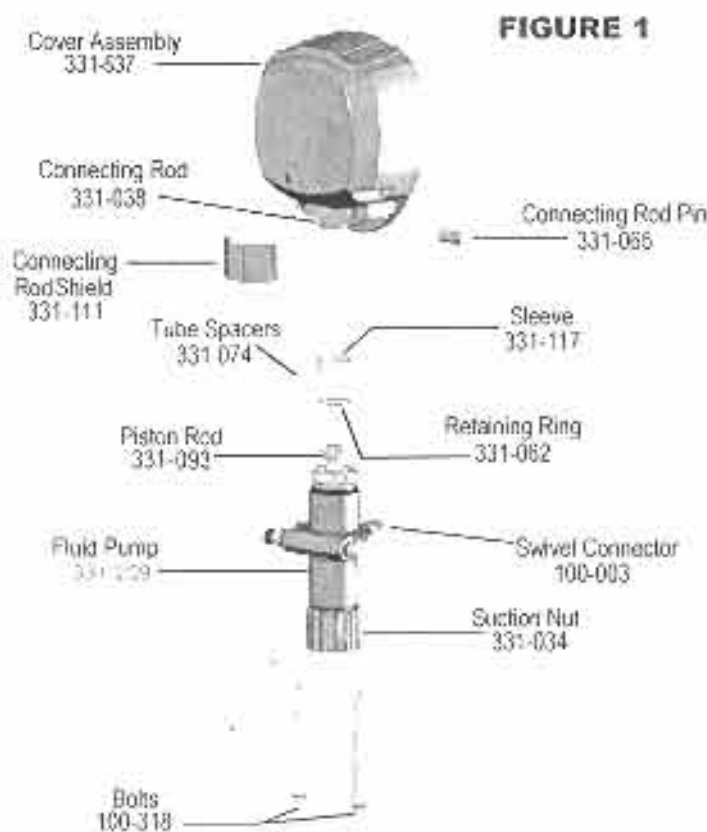

Fluid Pump Reinstall

Refer to Figure 1 & 4

1. Loosen the packing nut and ensure that the piston rod (331-093) is in its upper position in the fluid pump body (331-011). Slip the sleeve (331-117) & the retaining ring (331-062) over the piston rod.
2. Push the piston rod up into the connecting rod (331-038) & align the holes. Insert the connecting rod pin (331-065) through the connecting rod & piston. Slip the sleeve up over the connecting rod pin and insert the retaining ring into the groove on the connecting rod.
3. Push the two bolts (100-318) through the tube spacers (331-074) & screw them into the cover assembly (331-234). Using a 1/2" wrench, tighten the two bolts evenly (alternating between them) until you reach 20 ft-lbs.
4. Reassemble lower suction valve assembly by placing the suction seat (331-409), O-ring (106-011), suction ball (331-030) & suction ball guide (331-029) in the suction nut (331-034) & screw onto fluid pump body.
5. Start the machine and operate slowly to check the piston rod for binding. Adjust the two bolts, holding the fluid pump body to the cover assembly, if necessary. This will eliminate any binding.
6. Tighten the packing nut clockwise until resistance is felt against the Belleville Springs, then go 3/4 of a turn more. Put five drops of Airlessco Throat Seal Oil into the packing nut.
7. Run the machine at full pressure for several minutes. Release the pressure by following the Pressure Relief Procedure & readjust the packing nut per step 6 above.
8. Install the connecting rod shield (331-111) so that the small hole is in the upper right hand corner.

Servicing the Piston Rod - Outlet Valve

DISASSEMBLY OF THE OUTLET VALVE REFER TO FIGURE 3

1. Disconnect the Fluid Pump following instructions on page 17.
2. Place piston holder (331-195) in a vise. Slide piston into the holder & lock in place with a 3/8" dowel (331-196).
3. Use a 1/4" allen wrench to unscrew the outlet seat retainer (331-026) from the piston.
4. Remove the outlet seat (331-026), O-ring (331-100) and outlet ball (331-027).
5. Inspect outlet ball & seat for wear. Replace as necessary.
6. While piston is still locked in the holder, install parts back into the piston in the following order:

ball, outlet seat and O-ring

Before reinstalling the outlet seat support, apply two drops of Loctite No. 242 (blue) on the threads & torque to 20 ft-lbs.

NOTE: Vorlessen LP pump tool kit 188-197 is suggested for this task. Kit includes: Packing Tightening Bar (189-211), Packing Removal Tool (331-151), Piston Holder (331-195), 3/8" dowel (331-196).

FIGURE 3

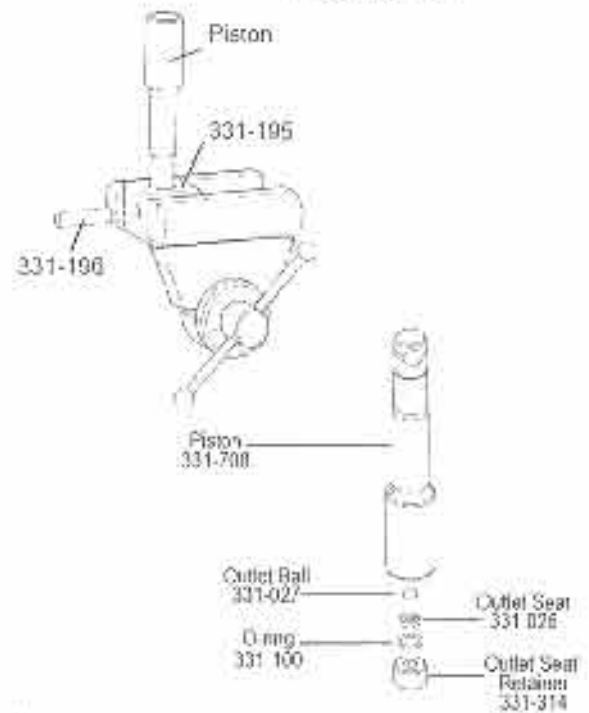

Servicing the Suction Assembly

REFER TO FIGURE 4

1. Un-thread and remove suction nut from the fluid pump body.
2. Remove suction seat (331-409), O-ring (106-011), suction ball (331-030) and suction retainer (331-029).
3. Clean all parts and inspect them for wear or damage, replacing parts as needed.
4. Clean inside of the fluid pump body.
5. Reassemble lower suction valve assembly by placing the suction seat (331-409), O-ring (106-011), suction ball (331-030) & suction ball guide (331-029) in the suction nut (331-034) &

FIGURE 4

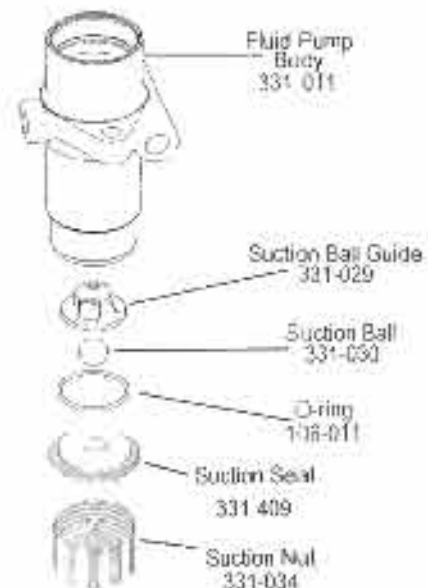

Packing Replacement Procedures

Replacement Instructions:

Fluid Pump Removal - Refer to Figure 1

1. Follow the Pressure Relief Procedure on page 10.
2. Flush material you are spraying out of the machine.
3. Remove the connecting rod shield (331-111).
4. Move the piston rod (331-093) to its lowest position by cycling pump slowly.
5. Remove the retaining ring (331-062) from the connecting rod (331-038) and slide the sleeve (331-117) down revealing the connecting rod pin (331-065).
6. Remove the suction tube assembly from the fluid pump (331-209) by unscrewing the suction nut (331-034) with the packing adjustment tool.
7. Using a 1/2" wrench unscrew the two bolts (100-318) from the cover assembly (331-234). The fluid pump (331-209) will be hanging loosely at this point.
8. Remove the connecting rod pin (331-065) out of the connecting rod (331-038), allowing the removal of the fluid pump (331-209) from the machine.

Disassembly of the Fluid Pump - Figure 6

1. Unscrew & remove the packing nut (331-037).
2. Push the piston rod (331-708) down through the packings & out of the pump.
3. Now push the packing removal tool (331-465) up through the pump & remove from the top bringing packings, spacer & springs along with it, leaving fluid body (331-011) empty.

**Make sure all old packings & glands have been removed from fluid pump.*

4. Clean inside of fluid body (331-011).
5. Disassemble all parts & clean for reassembly. Discard any old packings.
6. Lubricate leather packing in lightweight oil for 10 minutes prior to reassembly.







Disassembly of the Outlet Valve - Figure 3

1. Place piston holder (331-195) in a vise. Slide piston into the holder & lock in place with a 3/8" dowel.
2. Use a 1/4" allen wrench to unscrew the outlet seat retainer (331-026) from the piston.
3. Remove the outlet seat (331-026), O-ring (331-100) and outlet ball (331-027).
4. Inspect outlet ball & seat for wear. Replace as necessary.
5. While piston is still locked in the holder, install parts back into the piston in the following order:

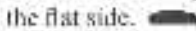
ball, outlet seat and O-ring

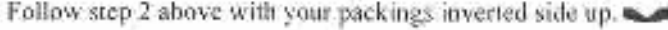
Before reinstalling the outlet seat support, apply two drops of Loctite No. 242 (blue) on the threads & torque to 20 ft-lbs.

REASSEMBLY - Figure 5 & 6

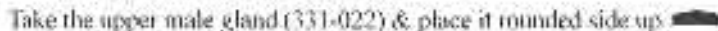
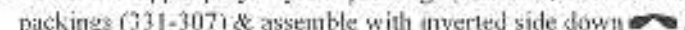
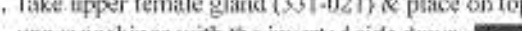
1. Take lower male gland (331-014) & place it down on the flat side. 
2. Take three of the lower polyethylene packings (331-016) & two of the leather packings (331-306) & place onto the male gland in the following order with the inverted side down  Polyethylene, leather, polyethylene, leather, polyethylene.
3. Take the female adaptor (331-305), which is inverted on both sides  & place it on top of your assembled lower packings.
4. Follow step 2 above with your packings inverted side up. 
5. Take the second lower male gland and place it on top of your assembled packings with the rounded side down 
6. Take assembled glands & packings (13 pieces) & slide on to the lower half of the piston.
7. Take the spacer (331-018) & slide over the top of the piston (it doesn't matter which direction it sits), falling onto lower packings.
8. Take three Belleville Springs (331-025) & slide over the top of the piston in the following order:
 - * First spring, curve facing down 
 - * Second spring, curve facing up 
 - * Third spring, curve facing down 
9. Take the upper male gland (331-022) & place it rounded side up 
10. Take three upper polyethylene packings (331-025) & two leather packings (331-307) & assemble with inverted side down  on to the male gland in the following order:
polyethylene, leather, polyethylene, leather, polyethylene.
11. Take upper female gland (331-021) & place on top of the assembled upper packings with the inverted side down. 
12. Take assembled upper glands & packings (7 pieces) & slide on over the top of the piston, making sure inverted sides are down.
13. Take the packing holder (331-019) & replace the white O-ring (106-009) & the black O-ring (106-010) with new ones from the packing kit.
14. Slide the packing holder over the top of the upper packings so they fit inside.
15. Lubricate inside of the fluid pump body & the outside of the packings with a light weight oil.
16. Slide completed assembly into fluid pump body (331-011)

** To keep packings secured in correct position, hold the pump body upside down & push the completed assembly upwards into the pump body. Once placed inside, tilt pump body back up to keep all pieces in.*

17. Tighten packing nut (331-037) onto the top of the fluid pump body & tighten until you feel slight resistance against the Belleville Springs (331-025). Using the Packing Adjustment Tool (189-211), tighten another 3/4 of a turn.

Fluid Pump Reinstallation - Figure 1 & 4

1. Loosen packing nut & ensure that the piston rod (331-093) is in its upper position in the fluid pump body (331-011). Slip the sleeve (331-117) & the retaining ring (331-062) over the piston rod.
2. Push piston rod up into the connecting rod (331-038) & align the holes. Insert the connecting rod pin (331-065) through the connecting rod & piston. Slip the sleeve up over the connecting rod pin & insert retaining ring into the groove on the connecting rod.

Packing Replacement Procedures

3. Push the two bolts (100-318) through the tube spacers (331-074) & screw into the cover assembly (331-234). Using a 1/2" wrench, tighten the two bolts evenly (alternating between them) until you reach 20 ft.-lbs.
4. Reassemble lower suction valve assembly by placing the suction seat (331-409) O-ring (106-011), suction ball (331-030) and suction ball guide (331-029) in the suction nut (331-034) & screw onto the fluid pump body.
5. Start the machine & operate slowly to check the piston rod for binding. Adjust the bolts, holding the fluid pump body to the cover assembly, if necessary. This will eliminate any binding.
7. Tighten packing nut clockwise until resistance is felt against the Belleville Springs, then go 3/4 of a turn more. Put five drops of Airlessco Throat Seal Oil into the packing nut.
7. Run the machine at full pressure for several minutes. Release the pressure by following the Pressure Relief Procedure & readjust the packing nut per step 6 above.
8. Install the connecting rod safety shield (Fig. 1 Part # 331-111) so that the small hole is in the upper right hand corner.

FIGURE 5

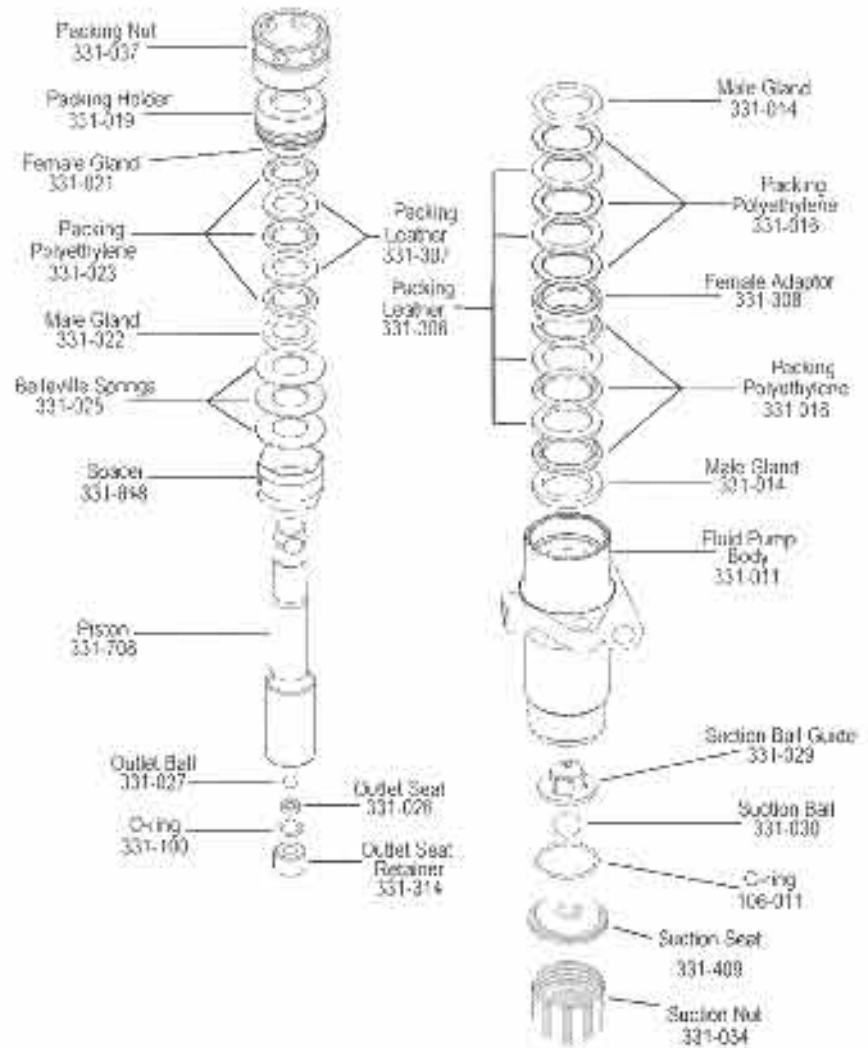
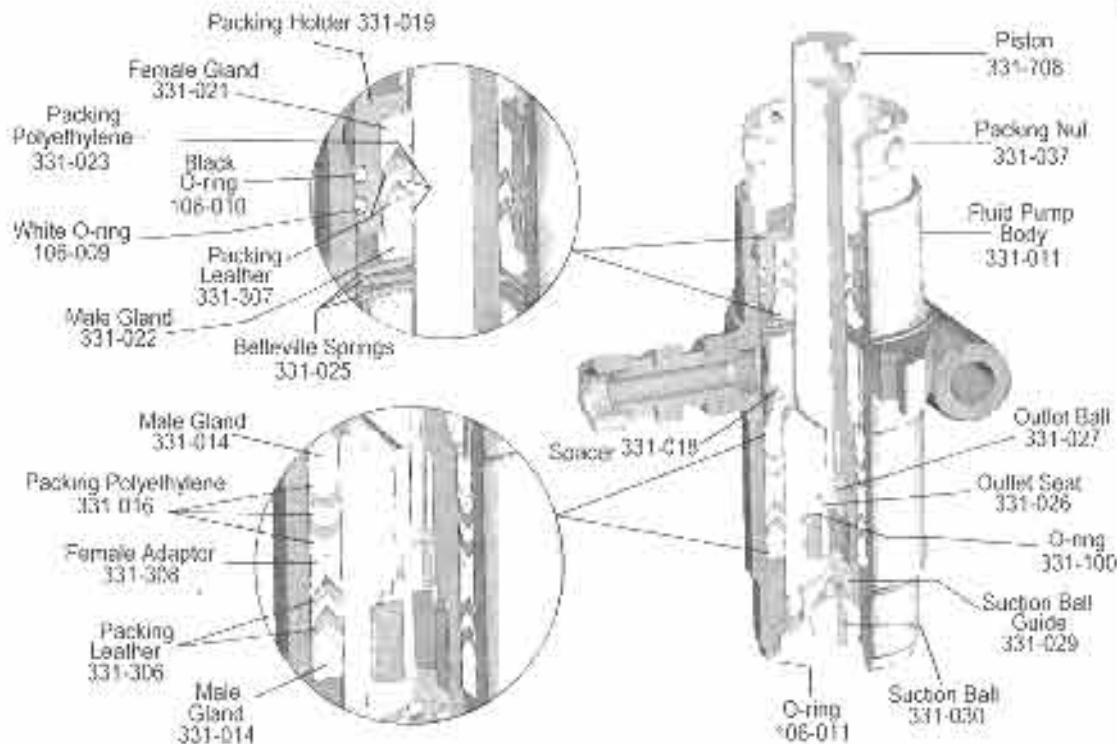

FIGURE 6



Inspection & Replacement of Control Valve, Ball & Seat

See diagram on page 24 for replacement parts list.

1. Use a wrench to unscrew the control valve with ring seal.
2. Make sure that the control valve knob turns freely and that its stem is not worn unevenly, mushroomed or otherwise damaged.
3. Remove TC guide, verify that it is unbroken, clean and notch side is up.
4. Remove control ball. Inspect for any cuts, scratches, chips, rust or other damage.
5. Use a 7/16" allen wrench to unscrew the control seat from the valve body. Clean seat and inspect bevel edge for damage. Also ensure that the gasket on the underside of the seat is intact.
6. If no obvious damage to the control ball and seat, place ball into seat and fill with water. If water leaks out between ball and seat, they must be replaced.
7. Replace control valve, ball, seat and/or TC guide as necessary.
8. Clean and inspect valve body opening, where the control seat was installed.
9. Grease valve body opening with multipurpose grease. →
10. Screw control seat into valve body and torque to 85 ft-lbs.
11. Place TC guide into control seat with notched side up.
12. Drop control ball into TC guide.
13. Screw control valve with ring seal into pump head. Torque to 15 ft-lbs.
14. If a new control valve, ball or seat is installed, complete the Pressure Calibration Procedure.

A repair kit with the control ball and seat is available as KIT-3-3100.

Pressure Control Calibration

DO NOT USE THIS PROCEDURE WITHOUT A TEST GAUGE!

1. Install a gun, flexible airless hose and Airlessco part # 111-045 glycerin filled test gauge onto unit.
2. Prime unit.
3. Turn the control valve knob fully clockwise (maximum pressure setting).
4. Read the gauge, it should be approximately 2500 PSI.
5. If maximum pressure is incorrect, remove the black plastic cap from the control valve knob. Insert a 7/16" allen wrench into the control valve knob set screw, turn clockwise to increase pressure and counter-clockwise to decrease pressure. Replace black plastic cap.
6. NEVER set the maximum pressure above 2500 PSI.

Gear Box Assembly - Part No. 305-196

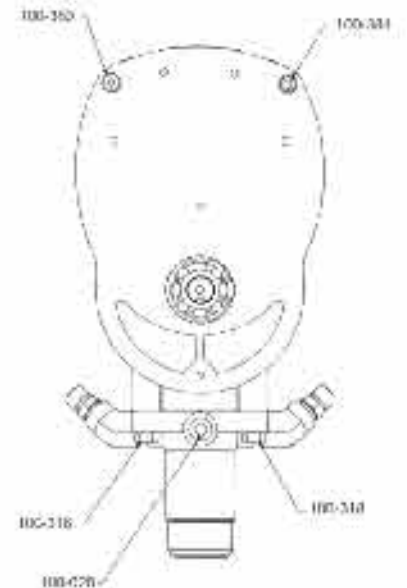
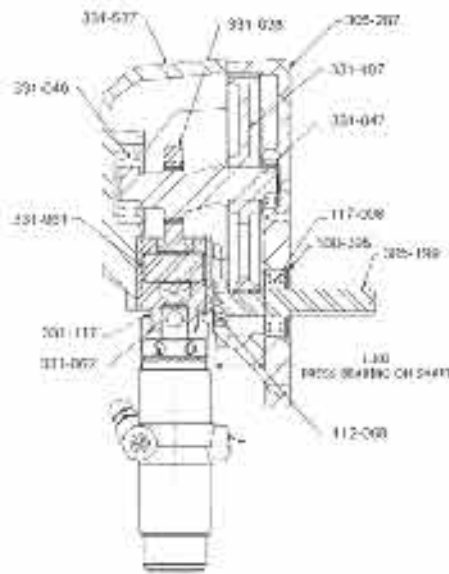
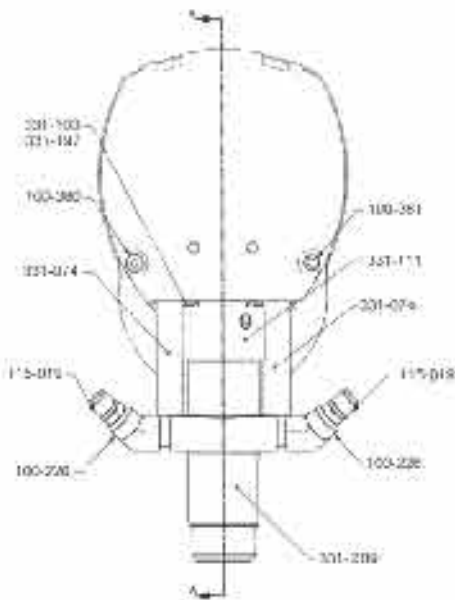

Part Number	Description	Part Number	Description
100-028	Pipe Plug	331-047	Ball Bearing
100-226	45 degree Elbow	331-061	Sleeve Bearing
100-318	HXHD Screw	331-062	Retaining Ring
100-380	Screw	331-074	Spacer
100-381	Screw	331-103	Flat Washer
100-398	Retaining Ring	331-111	Front Shield
112-068	Ball Bearing	331-117	Sleeve
115-019	Hose Connector	331-197	FLPHHD Screw
117-008	Ball Bearing	331-209	Pait Pump Ass'y
305-199	Shaft Pinion	331-407	Crank Ass'y
305-287	Machined End Bell	331-537	Machined Cover
331-038	Crosshead Ass'y	* Not Shown	
331-046	Ball Bearing	331-132	Grease

Spray Gun Assembly - Part No. 305-280

Part Number	Description
100-011	Airless 1/4" x 50' Hose
116-103	Cable Retainer Spring
120-115	008 Silver Gun w/o Tip
305-275	Gun Mount Ass'y
305-280	Spray Gun Assembly
561-025	Rev-Tip Male Seal
561-026	Rev-Tip Seal
563-317ST	Striping Tip
560-517	Painting Tip (not installed)

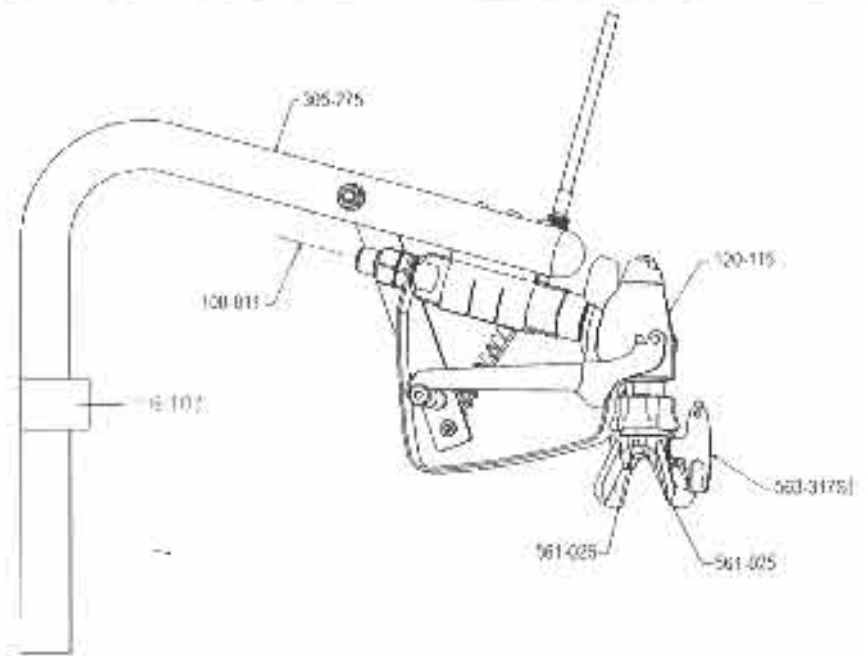

Gun Mount Assembly - Part No. 305-275

Part Number	Description
100-342	3/21 x 1.25 LG Screw
116-100	Compression Spring
119-049	HexScrew 25-20UNC-2A x 1.88 LG.
119-050	Screw Pan HD
119-052	Hex Lock Nut
136-217	Jam Nut .250 nylon locking
140-045	Jam Nut .250
143-027	Ball Guide
305-077	Cable Ass'y
305-079	Wire Swivel Ass'y
305-089	Cable Sleeve
305-141	Cable Adjustor
305-142	Lever Ass'y
305-159	Sleeve Bearing
305-161	Spacer
305-272	Gun Mount Tube
305-273	Spacer .250
305-274	Trigger Lever
305-276	Spring Clip
331-103	Flat Washer 1/4

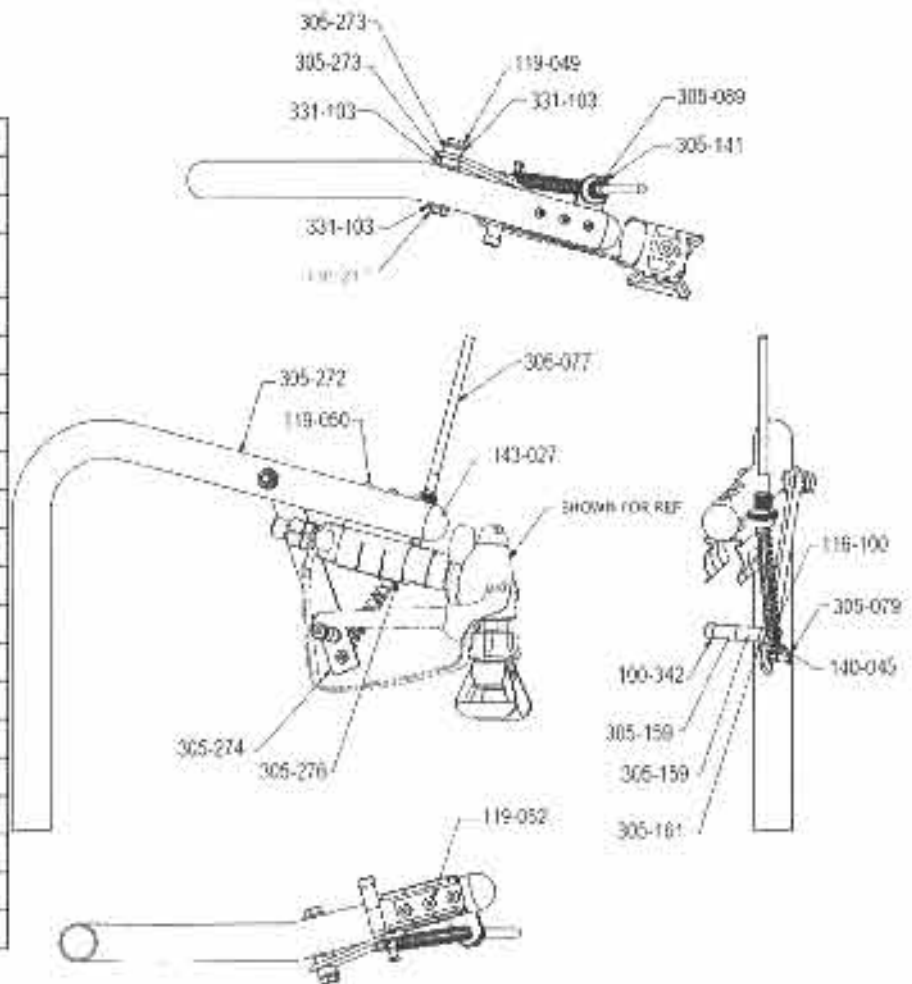

Bypass Valve Assembly Part No. 305-264

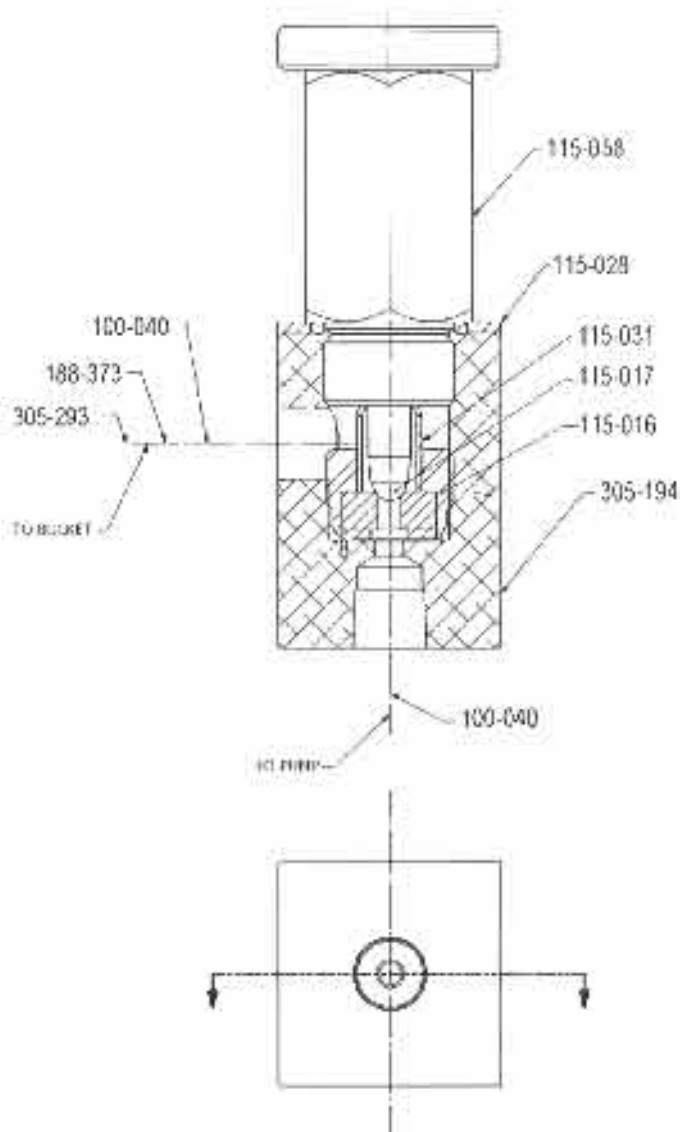

Part Number	Description	Qty.
100-040	Hose Whip	2
* 115-016	Control Valve Seat Ass'y	1
* 115-017	Ball	1
115-058	Control Valve	1
115-028	Stat-O-Seal	1
115-031	Guide T.C.	1
188-377	Return Tube	1
305-194	PR Regulator Housing	1

* Indicates parts included in repair KIT-3-3100

Suction Assembly Part No. 331-290

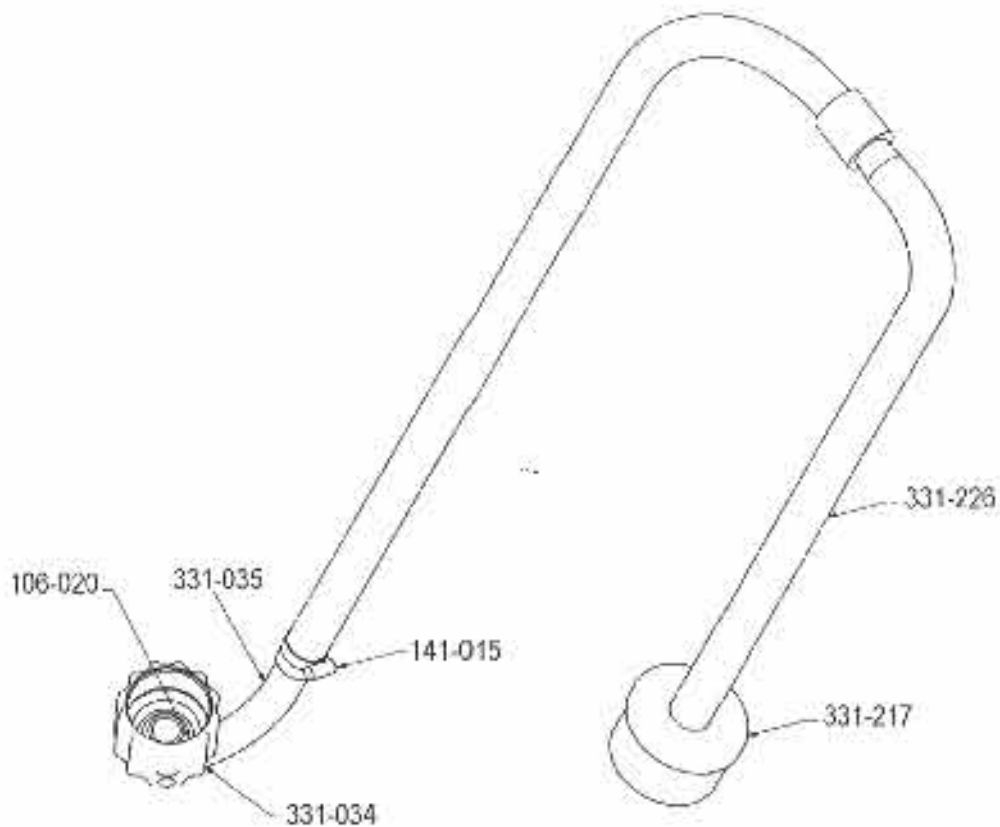

Part Number	Description	Qty.
106-020	Teflon O-Ring	1
141-015	Hose Clamp (some models only)	1
331-034	Suction Nut	1
331-035	Suction Elbow	1
331-217	Suction Filter	1